

BUILDING STRENGTH™

REBAR SPLICING
HANDBOOK

CONCRETE
CONSTRUCTION
PRODUCTS

 **DAYTON**[®]
SUPERIOR



General and Technical Information.....	1
Safety Notes and Product Application	1
Dayton Superior Technical Assistance	1
Table 1.1 Reinforcing Bar Data.....	2
Table 1.2 Mechanical Requirements for Standard ASTM Deformed Reinforcing Bars.....	2
Table 1.3 Mechanical Splice ACI and ICC Code Requirements.....	3
Table 1.4 Deformation Requirements for Standard ASTM Deformed Reinforcing Bars	3
Table 1.5 Chemical Composition Requirements for Standard ASTM Deformed Reinforcing Bars.....	3
Table 1.6 Grade 60 Rebar.....	4
Table 1.7 Recommended End Hooks.....	4
Tables 1.8 and 1.9 Recommended Industry Practice for Stirrup and Tie Hooks	5
Table 1.10 Development ℓ_{dh} of Standard Hooks	5
Table 1.11 Tension Lap Splice Lengths – Grade 60 Uncoated Bars	6
Table 1.12 Metric Conversion Factors.....	7
Splicing Selection Guide	8
Threaded Splicing Systems.....	9
DBDI® Splice System.....	9
Recommended Dowel Bar and Dowel-In Sizes.....	10
Required Development and Lap Lengths for Grade 60, Uncoated Bottom Reinforcement in Normal Weight Concrete	10
Typical Threaded Splicing Applications.....	10
D101 Dowel-In, D102 90° Hooked Dowel-In, D103 180° Hooked Dowel-In, D104 Double-Ended Dowel-In	11
D101A Dowel Bar, D102A 90° Hooked Dowel Bar, D103A 180° Hooked Dowel Bar, D104A Double-Ended Dowel Bar	12
Recommended Dowel Bar and Dowel-In Sizes.....	13
Typical DBDI Installation	14
D106 DBDI Weldable Coupler	15
D50 DBR Coupler System	16
D50 DBR Coupler and DBR Setting/Splice Bars.....	16
D51 DBR Straight Bar Threaded One End.....	17
D54 DBR Straight Bar Threaded Both Ends.....	17
D52 DBR 90° Hook Bar and D53 180° Hook Bar Threaded One End	17
D51A DBR Straight Bar Threaded One End.....	18
D54A DBR Straight Bar Threaded Both Ends.....	18
D52A DBR 90° Hook Bar and D53A 180° Hook Bar Threaded One End	18
How To Install the DBR Coupler System	19
Bar Lock®	21
D250SCA Bar Lock® S/CA-Series Couplers	22
D250L Bar Lock® L-Series Coupler	22
D250XL Bar Lock® XL-Series Coupler.....	23
D220 Bar Lock® Transition Couplers	23
D251L Bar Lock® L-Series End Anchor	24
D252L Bar Lock® L-Series Coupler.....	25
D630 Bar Lock® Compression Only Coupler.....	26
D260 Bar Lock® Weldable Couplers.....	27
Typical Bar Lock® Coupler Installation.....	28
Taper-Lock®	30
The Taper-Lock® System.....	30
D310 Taper-Lock® Standard Coupler	31
Installation: D310 Taper-Lock Standard Coupler	32
D320 Taper-Lock® Transitional Coupler	33
Installation: D320 Taper-Lock Transitional Coupler	34

Taper-Lock®	cont'd
D330 Taper-Lock® Positional Coupler	35
Installation: D330 Taper-Lock Positional Coupler	36
D340 Taper-Lock® Flange Coupler	37
D350 Taper-Lock® End Anchor Disc	38
D351 Taper-Lock® End Anchor Disc	39
D358 Taper-Lock® Female Bolt Head	40
D360 Taper-Lock® Weldable Coupler	41
D368 Taper-Lock® Form Saver	42
D370 Taper-Lock® Threaded Bar	43
Sleeve-Lock® Grout Sleeve	45
D410 Sleeve-Lock® Grout Sleeve	45
D490 Sleeve-Lock® Grout	46
Turbo Grout® LT 12	46
D487 Sleeve-Lock® Seal Plug	46
D491 Sleeve-Lock® Form Plug	46
D492 Sleeve-Lock® ¾" SCH40 PVC	46
D493 Sleeve-Lock® Port Plug	46
End Anchorage	48
End Anchorage System	48
D158B Plain End Anchor	49
D158C Female End Anchor	49
D158D Male End Anchor	49
D158E Double End Anchor	49
D158 Two Piece End Anchor	50
D108 Headed Dowel-In	51
D108A Headed Dowel Bar	51
D58 Headed DBR Male Bar	52
D58A Headed Dowel Bar	53
Miscellaneous	55
D42 Bag Ties	55
PC110 Rebar Safety Cap	55
D46 Tie Wire	55
D48 Sure-Guard Rebar Protective Cap	55
D55 MetalStrip™	56
How to Order D55 MetalStrip	57
P154 DB Attachment Magnet	58
F72 Threaded Steel Setting Plug	58
F74 Threaded Plastic Setting Plug	58
Supports for Rebar and Wire Mesh	59
Index	63

Safety Notes and Product Application

Dayton Superior strives to ensure that all products supplied from its manufacturing plants meet or exceed the safety requirements inherent in the proper use of its products. However, the performance of a product can be greatly affected by the manner in which the product is used. It is imperative that the user be instructed in the proper installation and use of the products displayed in this handbook prior to job application.

Product production runs are constantly sampled and tested to assure the user a high standard of quality. Samples are tested in Dayton Superior test facilities or at independent testing laboratories. The safe working loads listed in this handbook were determined from the results of the testing program and other industry sources.

Dayton Superior publishes the safe working loads and the associated minimum safety factors of its products and strongly advises that the minimum safety factors not be compromised. When there are unusual job conditions, the minimum safety factors must be increased by the user. Refer to the provisions of the American National Standards Institute (ANSI A 10.9), the Occupational Safety and Health Administration (OSHA) Act, Part 1910, and the American Concrete Institute (ACI) Recommended Practice for Concrete Formwork (ACI 347) and ACI 318 Building Code when considering product safety factors.

DAYTON SUPERIOR TECHNICAL ASSISTANCE

Dayton Superior Technical Assistance has trained personnel to service inquiries, take-offs and details for the users of Dayton Superior quality splicing accessories.

TECHNICAL ASSISTANCE: 877-266-7732

Table 1.1 Reinforcing Bar Data

Reinforcing Bars Size Designations and Nominal Dimensions											
Bar Size Designation			Nominal Dimensions			Ultimate Specified Tensile Capacity (lb)					
US	Metric (mm)	CN (M)	Dia (in)	Area (in ²)	Weight (lb/ft)	ASTM A615				ASTM A706	
						Grade 60	Grade 75	Grade 80	Grade 100	Grade 60	Grade 80
#4	[13]	[10]	0.500	0.20	0.688	18,000	20,000	21,000	23,000	16,000	20,000
#5	[16]	[15]	0.625	0.31	1.043	27,900	31,000	32,550	35,650	24,800	31,000
#6	[19]	[20]	0.750	0.44	1.502	39,600	44,000	46,200	50,600	35,200	44,000
#7	[22]	–	0.875	0.60	2.044	54,000	60,000	63,000	69,000	48,000	60,000
#8	[25]	[25]	1.000	0.79	2.670	71,100	79,000	82,950	90,850	63,200	79,000
#9	[29]	[30]	1.128	1.00	3.400	90,000	100,000	105,000	115,000	80,000	100,000
#10	[32]	–	1.270	1.27	4.303	112,500	125,000	131,250	143,750	100,000	125,000
#11	[36]	[35]	1.410	1.56	5.313	140,400	156,000	163,800	179,400	124,800	156,000
#14	[43]	[45]	1.693	2.25	7.650	202,500	225,000	236,250	258,750	180,000	225,000
#18	[57]	[55]	2.257	4.00	13.600	360,000	400,000	420,000	460,000	320,000	400,000

Note: The nominal dimensions of a deformed bar are equivalent to those of plain, round bar having the same weight (mass) per foot (meter) as the deformed bar. Nearly all reinforcing bars currently produced in the USA are marked with the metric numbers 13, 16, etc., to designate bar sizes. These bar numbers correspond to the traditional designations, 4, 5, etc., as shown in the table above. ACI 318-14 still lists the bar sizes traditionally using #3 - #18 designations. The tables in this manual typically designate bar sizes as #3[#10] or just with the traditional designation, #3.

Table 1.2 Mechanical Requirements for Standard ASTM Deformed Reinforcing Bars

Note: For the mechanical requirements of rail-steel and axle-steel bars, see ASTM specifications A616 and A617, respectively.

Type of Steel and ASTM Designation	Bar Number Range	Grade ¹	Minimum Yield Strength ² (psi)	Maximum Yield Strength ² (psi)	Minimum Tensile Strength (psi)	Minimum % Elongation in 8in	Cool Bend Test Pin Diameter ³ (d = nominal diameter of specimen)
ASTM A615 Carbon Steel	3-6	40	40,000	N/A	60,000	#3 - 11% #4-6 - 12%	#3-5 - 3½ d #6 - 5d
	3-11 14 18	60	60,000		90,000	#3-6 - 9% #7-8 - 8% #9-11, 14, 18 - 7%	#3-5 - 3½ d #6-8 - 5d #9-11 - 7d #14, 18 (90°) - 9d
		75	75,000		100,000	#3-8 - 7% #9-11, 14, 18 - 6%	#3-8 - 5d #9-11 - 7d #14, 18 (90°) - 9d
		80	80,000		105,000	#3-8 - 7% #9-11, 14, 18 - 6%	#3-8 - 5d #9-11 - 7d #14, 18 (90°) - 9d
		100	100,000		115,000	#3-8 - 7% #9-11, 14, 18 - 6%	#3-8 - 5d #9-11 - 7d #14, 18 (90°) - 9d
ASTM A706 Low-Alloy Steel	3-11 14 18	60	60,000	78,000	80,000 ⁴	#3-6 - 14% #7-11 - 12% #14, 18 - 10%	#3-5 - 3d #6-8 - 4d #9-11 - 6d #14, 18 - 8d
		80	80,000	98,000	100,000 ⁴	#3-11 - 12% #14, 18 - 10%	#3-5 - 3½ d #6-8 - 5d #9-11 - 7d #14, 18 - 9d

1. Minimum yield strength designation (ksi)
 2. Yield point or yield strength, see ASTM specifications
 3. Test bends 180°, unless noted otherwise
 4. Tensile strength shall not be less than 1.25 times the actual yield strength (ASTM A706 only)

Table 1.3 Mechanical Splice ACI and ICC Code Requirements

Mechanical Splice ACI and ICC Code Requirements					
ASTM Specification	Bar Grade	Specified Yield Strength (psi)	Specified Tensile Strength (psi)	Mechanical Splice Requirement (psi)	
				Type 1	Type 2
A615	40	40,000	60,000	50,000	60,000
	60	60,000	90,000	75,000	90,000
	75	75,000	100,000	93,750	100,000
	80	80,000	105,000	100,000	105,000
	100	100,000	115,000	115,000	115,000
A706	60	60,000	80,000	75,000	80,000
	80	80,000	100,000	100,000	100,000

Mechanical Splice Requirement –

ACI 318 Chapters 18 and 25 state the requirements for mechanical splices. They are:

Type 1 Mechanical Splice shall develop in tension and compression as required at least 125% of the specified yield of the bar.

Example: For ASTM A615 Grade 60 bar: $1.25 \times 60,000\text{psi} = 75,000\text{psi}$

Therefore, a splice test exceeding 75,000 psi meets the Type 1 requirement for A615 Grade 60 bar.

Type 2 Mechanical Splice shall conform to Type 1 requirements and develop 100% of the specified ultimate strength of the bar being spliced.

Example: For ASTM A615 Grade 60 bar: $1.00 \times 90,000\text{psi} = 90,000\text{psi}$

Therefore, a splice test exceeding 90,000 psi meets the Type 1 and Type 2 requirement for A615 Grade 60 bar.

Table 1.4 Deformation Requirements for Standard ASTM A615 and A706 Deformed Reinforcing Bars

Bar Size Designation			Max. Average Spacing, inc.	Max. Average Height, in.	Maximum* Gap, in.
US	Metric (mm)	CN (M)			
#3	[10]	–	0.262	0.015	0.143
#4	[13]	[10]	0.350	0.020	0.191
#5	[16]	[15]	0.437	0.028	0.239
#6	[19]	[20]	0.525	0.038	0.286
#7	[22]	–	0.612	0.044	0.334
#8	[25]	[25]	0.700	0.050	0.383
#9	[29]	[30]	0.790	0.056	0.431
#10	[32]	–	0.889	0.064	0.487
#11	[36]	[35]	0.987	0.071	0.540
#14	[43]	[45]	1.185	0.085	0.648
#18	[57]	[55]	1.58	0.102	0.864

* Chord of 12.5% of nominal perimeter

Table 1.5 Chemical Composition Requirements for Standard ASTM Deformed Reinforcing Bars

Type of Steel and ASTM Designation	Condition*	Element									
		Carbon (C)	Manganese (Mn)	Phosphorus (P)	Sulphur (S)	Silicon (Si)	Copper (Cu)	Nickel (Ni)	Chromium (Cr)	Molybdenum (Mo)	Vanadium (V)
Billet-Steel A615	1	X	X	X	X						
	2			0.06%							
	3			0.075%							
Low-Alloy Steel A706	1	X	X	X	X	X	X	X	X	X	X
	2	0.30%	1.50%	0.035%	0.045%	0.50%					
	3	0.33%	1.56%	0.043%	0.053%	0.55%					

*CONDITION DEFINITIONS:

1. Analysis required of these elements for each heat.
2. Maximum allowable chemical content for each heat.
3. Maximum allowable chemical content for finished bar.

Table 1.6 Grade 60 Rebar

ACI Compression Development and Lap Splice Lengths for $f'_c = 3,000$ psi to 5,000 psi

Notes:

- Tabulated values are based on Grade 60 reinforcing bars and normal-weight concrete.
- Compression development lengths and compression lap splice lengths are based on ACI 318-14, Sections 25.4 and 25.5, respectively. Lengths are in inches.
- For compression development lengths, if bars are enclosed in spirals or ties conforming to ACI 318-14, Section 25.4.9.3, then a modification factor of 0.75 may be applied but the resulting length must not be less than 8 in.
- For compression lap splice lengths:
 - If bars are enclosed in a tied-reinforced compression member conforming to ACI 318-14, Section 10.7.5.2.1(a), then a modification factor of 0.83 may be applied but the resulting length must not be less than 12 in.
 - If bars are enclosed in a spirally-reinforced compression member conforming to ACI 318-02, Section 12.17.2.5, then a modification factor of 0.75 may be applied but the resulting length must not be less than 12 in.
 - The tabulated lengths are applicable for all concrete strengths of at least 3,000 psi.
- ACI 318-14 does not allow lap splices of #14 and #18 bars. Compression lap splices of #14 or #18 bars to #11 or smaller bars are permitted in accordance with ACI 318-14 section 25.5.5.3.

Bar Size Designation			Compression Development Lengths per f'_c			Compression Lap Splice Length
US	Metric (mm)	CN (M)	$f'_c = 3,000$ psi	$f'_c = 4,000$ psi	$f'_c = 5,000$ psi	
#3	[10]	—	9	8	8	12
#4	[13]	[10]	11	10	9	15
#5	[16]	[15]	14	12	12	19
#6	[19]	[20]	17	15	14	23
#7	[22]	—	19	17	16	27
#8	[25]	[25]	22	19	18	30
#9	[29]	[30]	25	22	21	34
#10	[32]	—	28	24	23	38
#11	[36]	[35]	31	27	26	43
#14	[43]	[45]	37	32	31	N/A
#18	[57]	[55]	50	43	41	N/A

Table 1.7 Recommended End Hooks

All Grades: D = Finished bend diameter

Bar Size Designation			D (in.)	180° Hooks		90° Hooks
US	Metric (mm)	CN (M)		A or G	J	A or G
#3	[10]	—	2-1/2"	5"	3"	6"
#4	[13]	[10]	3"	6"	4"	8"
#5	[16]	[15]	3-3/4"	7"	5"	10"
#6	[19]	[20]	4-1/2"	8"	6"	1'-0"
#7	[22]	—	5-1/4"	10"	7"	1'-2"
#8	[25]	[25]	6"	11"	8"	1'-4"
#9	[29]	[30]	9-1/2"	1'-3"	11 1/4"	1'-7"
#10	[32]	—	10-3/4"	1'-5"	1'-1 1/4"	1'-10"
#11	[36]	[35]	12"	1'-7"	1'-2 3/4"	2'-0"
#14	[43]	[45]	18-3/4"	2'-3"	1'-9 3/4"	2'-7"
#18	[57]	[55]	24"	3'-0"	2'-4 1/2"	3'-5"

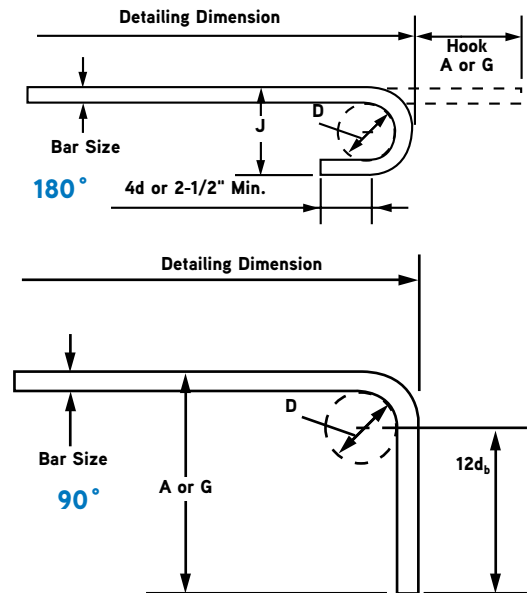

Tables 1.8 and 1.9 Recommended Industry Practice for Stirrup and Tie Hooks

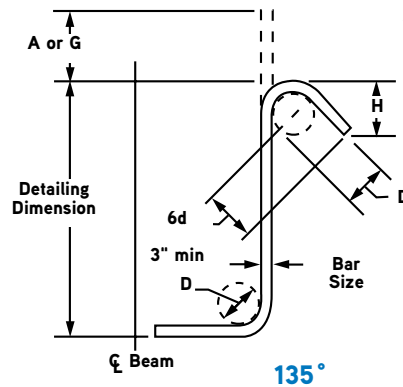
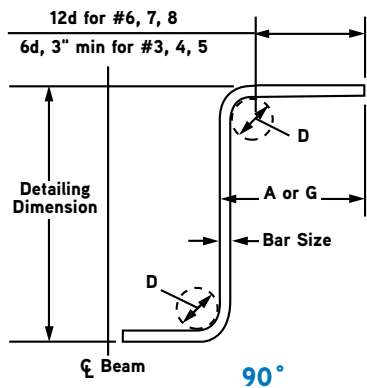

135° Seismic Stirrup/Tie Hooks

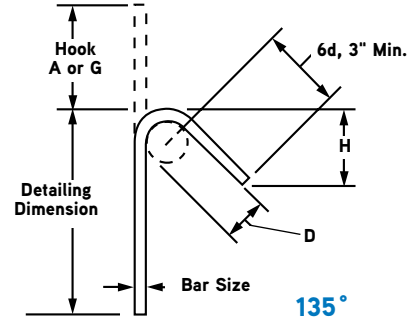

Table 1.8 Stirrup (Ties Similar)
Stirrup and Tie Hook Dimensions All Grades:

Bar Size Designation			D (in.)	90°		135°	
US	Metric (mm)	CN (M)		A or G	A or G	H*	
#3	[10]	—	1½"	4"	4"	2½"	
#4	[13]	[10]	2"	4½"	4½"	3"	
#5	[16]	[15]	2½"	6"	5-½"	3¾"	
#6	[19]	[20]	4½"	1'-0"	8"	4½"	
#7	[22]	—	5¼"	1'-2"	9"	5¼"	
#8	[25]	[25]	6"	1'-4"	10½"	6"	

*H dimension is approximate.

Table 1.9 135° Seismic Stirrup/Tie
Hook Dimensions All Grades: Seismic Stirrup/Tie Hooks

Bar Size Designation			135° Seismic Hook		
US	Metric (mm)	CN (M)	D (in.)	A or G	H*
#3	[10]	—	1½"	4¼"	3"
#4	[13]	[10]	2"	4½"	3"
#5	[16]	[15]	2½"	5½"	3¾"
#6	[19]	[20]	4½"	8"	4½"
#7	[22]	—	5¼"	9"	5¼"
#8	[25]	[25]	6"	10½"	6"

*H dimension is approximate.

Table 1.10 Development l_{dh} of Standard Hooks

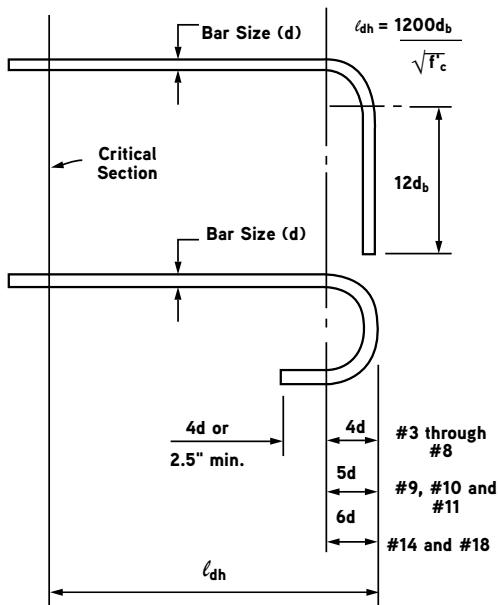

Table 1.10 ACI Hook Development Lengths
for $f'_c = 3,000$ to $5,000$ psi

Bar Size Designation			$f'_c = 3,000$ psi	$f'_c = 4,000$ psi	$f'_c = 5,000$ psi
US	Metric (mm)	CN (M)			
#3	[10]	—	9	7	7
#4	[13]	[10]	11	10	9
#5	[16]	[15]	14	12	11
#6	[19]	[20]	17	15	13
#7	[22]	—	19	17	15
#8	[25]	[25]	22	19	17
#9	[29]	[30]	25	22	19
#10	[32]	—	28	24	22
#11	[36]	[35]	31	27	24
#14	[43]	[45]	37	32	29
#18	[57]	[55]	50	43	39

Notes:

- Tabulated values based on Grade 60 reinforcing bars and normal weight concrete.
- Tension development lengths of standard hooks are based on ACI 318-14, Section 25.4.3. Lengths are in inches.
- For bar sizes #3 through #11 only:
 - If concrete cover conforms to ACI 318-14, Section 25.4.3.2, then a modification factor of 0.7 may be applied but the resulting length must not be less than $8d_b$ nor 6 in.
 - If hook is enclosed in ties or stirrups conforming to ACI 318-14, Section 25.4.3.2, then a modification factor of 0.8 may be applied but the resulting length must not be less than $8d_b$ nor 6 in.
- For epoxy-coated hooks, multiply the tabulated values by 1.2.

Table 1.11 Tension Lap Splice Lengths – Grade 60 Uncoated Bars

$f'_c = 3,000$ psi or greater, Normal Weight Concrete

DESIGN AND DETAILING DATA – ACI 318 Tension Lap Splice Lengths

Bar Size Designation			Lap Class	$f'_c = 3,000$ psi				$f'_c = 4,000$ psi				$f'_c = 5,000$ psi			
US	Metric (mm)	CN (M)		Top Bars		Other Bars		Top Bars		Other Bars		Top Bars		Other Bars	
				Case 1	Case 2	Case 1	Case 2	Case 1	Case 2	Case 1	Case 2	Case 1	Case 2	Case 1	Case 2
#3	[10]	–	A	22	32	17	25	19	28	15	22	17	25	13	19
			B	28	42	22	32	24	36	19	28	22	33	17	25
#4	[13]	[10]	A	29	43	22	33	25	37	19	29	22	33	17	26
			B	37	56	29	43	32	48	25	37	29	43	22	33
#5	[16]	[15]	A	36	54	28	41	31	47	24	36	28	42	22	32
			B	47	70	36	54	40	60	31	47	36	54	28	42
#6	[19]	[20]	A	43	64	33	50	37	56	29	43	33	50	26	38
			B	56	84	43	64	48	72	37	56	43	65	33	50
#7	[22]	–	A	63	94	48	72	54	81	42	63	49	73	37	56
			B	81	122	63	94	70	106	54	81	63	94	49	73
#8	[25]	[25]	A	72	107	55	82	62	93	48	72	55	83	43	64
			B	93	139	72	107	80	121	62	93	72	108	55	83
#9	[29]	[30]	A	81	121	62	93	70	105	54	81	63	94	48	72
			B	105	157	81	121	91	136	70	105	81	122	63	94
#10	[32]	–	A	91	136	70	105	79	118	61	91	70	105	54	81
			B	118	177	91	136	102	153	79	118	91	137	70	105
#11	[36]	[35]	A	101	151	78	116	87	131	67	101	78	117	60	90
			B	131	196	101	151	113	170	87	131	101	152	78	117
#14	[43]	[45]	N/A	121	181	93	139	105	157	81	121	94	140	72	108
#18	[57]	[55]	N/A	161	241	124	186	139	209	107	161	125	187	96	144

Notes:

- Tabulated values are based on Grade 60 reinforcing bars and normal-weight concrete.
- Tension development lengths and tension lap splice lengths are based on ACI 318-02, Sections 12.2.2 and 12.15, respectively. Tabulated values for beams or columns are based on transverse reinforcement and concrete cover meeting minimum Code requirements. Lengths are in inches.
- Cases 1 and 2, which depend on the type of structural element, concrete cover, and the center-to-center spacing of the bars, are defined as:

Beams or Columns	Case 1	Cover at least $1d_b$ and c.-c. spacing at least $2d_b$
	Case 2	Cover less than $1d_b$ or c.-c. spacing less than $2d_b$
All Others	Case 1	Cover at least $1d_b$ and c.-c. spacing at least $3d_b$
	Case 2	Cover less than $1d_b$ or c.-c. spacing less than $3d_b$

- Lap Class A values are the required tension development lengths, l_d ; lap splice lengths are multiples of tension development lengths; Class A - $1.0l_d$ and Class B = $1.3l_d$ (ACI 318-14, Section 25.5.2.1).
- Lap splices of #14 or #18 bars are not permitted. The tabulated values for those bar sizes are the tension development lengths.
- Top bars are horizontal bars with more than 12 inches of concrete cast below the bars.
- For lightweight aggregate concrete, multiply the tabulated values by 1.3; or when f_{ct} is specified, the factor is $6.7 \sqrt{f'_c} / f_{ct} \geq 1.0$.
- For epoxy-coated bars, multiply the tabulated values by one of the following factors:



Concrete Cover and Spacing	Top Bars	Other Bars
Cover $< 3d_b$ or c.-c. spacing $> 7d_b$	1.7 / 1.3 - 1.31	1.50
Cover $\leq 3d_b$ or c.-c. spacing $\leq 7d_b$	1.20	1.20

Table 1.12 Metric Conversion Factors

Quantity	To Convert From...	To...	Multiply By...
Length	mile	km	1.609 344*
	yard	m	0.9144*
	foot	m	0.3048*
	foot	mm	304.8*
	inch	mm	25.4*
Area	square mile	km ²	2.589 998
	acre	m ²	4046.873
	acre	ha	0.404 687 3
	square yard	m ²	0.836 127 4*
	square foot	m ²	0.092 903 04*
square inch	mm ²	645.16*	
Volume	acre foot	m ³	1233.489
	cubic yard	m ³	0.764 554 9
	cubic foot	m ³	0.028 316 85
	cubic foot	cm ³	28 316.85
	cubic foot	L	28.316 85
	100 board feet	m ³	0.235 973 7
	gallon	L	3.785 412
	cubic inch	cm ³	16.387 06
cubic inch	mm ³	16 387.06	
Mass	pound	kg	0.453 592 4
	ton (2,000 pounds)	kg	907.184 7
	kip	t	0.453 592 4
Mass/Unit Length	pound/foot	kg/m	1.488 164
Mass/Unit Area	pound/foot ²	kg/m ²	4.882 428
Mass Density	pound/foot ³	kg/m ³	16.018 46
Force	pound	N	4.448 222
	kip	kN	4.448 222
Force/Unit Length	pound/foot	N/m	14.593 90
	kip/foot	kN/m	14.593 90
Pressure, Stress	pound/foot ²	Pa	47.880 26
	kip/foot ²	kPa	47.880 26
	pound/inch ²	kPa	6.894 757
	kip/inch ²	MPa	6.894 757
	pound/inch ²	N/mm ²	0.006 895
kip/inch ²	N/mm ²	6.894 757	
Moment, Torque	foot-pound	N•m	1.355 818
	foot-kip	kN•m	1.355 818
Moment of Mass	pound-foot	kg•m	0.138 255 0
Moment of Inertia	pound-foot ²	kg•m ²	0.042 140 11
Second Moment of Inertia	inch ⁴	mm ⁴	416 231.4
Section Modulus	inch ³	mm ³	16 387.06
Temperature	°F	°C	(°F-32)5/9
Plane Angle	degree	rad	0.017 453 29

Note: Asterisk denotes exact number.

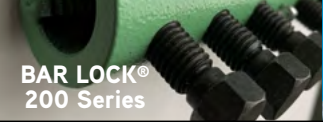
Splicing Selection Guide

	Two-piece splice system that offers a maximum strength splice without special tools or equipment.			Premier shear bolt coupler offering a high-strength connection with no bar end modification.			High-strength, taper-threaded, mechanical splice requiring no installation tools.			Grout-filled mechanical coupler providing a high-strength splice system for the precast industry.		
												
	50 Series	100 Series	100 Series	200 Series	200 Series	200 Series	300 Series	400 Series				
Application	DBR	DB/DI	D-158	Bar Lock SCA	Bar Lock L	Bar Lock XL	Taper-Lock	Sleeve Lock				
WALL TO SLAB CONNECTION	X	X	X				X					
WALL TO PRE-CAST BEAM CONNECTION	X	X	X				X					
COLUMN CONSTRUCTION	X	X	X	X	X	X	X	X				
EXTENSION/REPAIRS TO EXISTING STRUCTURES				X	X	X		X				
PRE-CAST ELEMENT TO PRE-CAST ELEMENT CONNECTION								X				
CLOSING OF ACCESS OPENINGS		X		X	X	X	X	X				
REBAR CAGE PRE-FABRICATION	X	X	X	X	X	X	X	X				
HOOK BARS TO PILE CONNECTION	X	X		X	X	X	X					
FATIGUE APPLICATIONS		X		X	X	X	X					
BAR END ANCHORS		X	X	X	X	X	X					
FORM SAVERS	X	X					X	X				
Qualification												
TYPE 1 GRADE 60	X	X	X	X	X	X	X	X				
TYPE 2 GRADE 60		X	X		X	X	X	X				
TYPE 1 & 2 GRADE 80						X	X					
GRADE 100							X					

DBDI® Splice System

IAPMO UES Listed Evaluation Report ER-319

The Dayton Superior DBDI Splice System is a two-piece, standard mechanical splicing product that eliminates protruding dowels. Typical applications include splicing reinforcement bars in monolithic structures, rebar anchorages, future expansion, and dowel bar substitution at construction joints.

The components of the system, the Dowel Bar (DB) and Dowel-In (DI), are manufactured from standard rebar material. Basic fabrication consists of forging and threading operations. No welding or machining is required and the threading operation does not reduce the nominal cross-sectional area of the bar. The completed splice obtains ultimate bar strengths and meets or exceeds all existing code requirements.

System Advantages

The patented DBDI Splice System has been engineered, tested, and proven to meet or exceed all field standards and design/engineering practices. The system is easy to use and readily identified as rebar material. The easy installation requires no special tools or machinery and simplifies the forming operations. There are no “extras,” such as wedges, nuts, collars or couplers required and routine cutting, bending, etc., can be easily handled in the field, if required.

The Dayton Superior DBDI Splice System Advantages:

- Strong
- Safe
- Easy to Use
- Eliminates Protruding Dowels
- Improves Forming Costs
- Reduces Forming and Stripping Hassles
- Saves Forms By Eliminating Drilling Holes
- No Forming Required

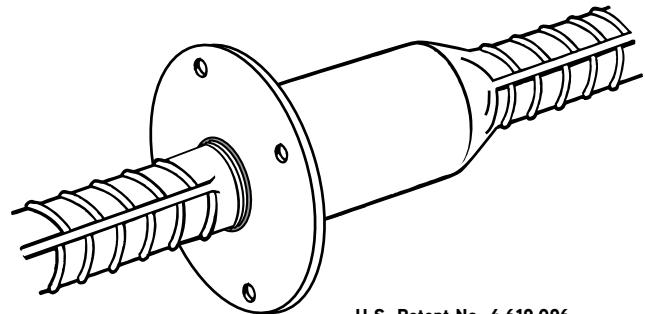

U.S. Patent No. 4,619,096

System Compliance

The DBDI Splice System complies with the following standards/specifications:

- ACI 318 Type 2
- IAPMO UES Listed Evaluation Report ER-319
- State Departments of Transportation
- Ministries of Transportation (Canada)
- Caltrans Ultimate Splice
- City of Los Angeles Department of Building and Safety
- AASHTO
- International Building Code (IBC)



Typical Splicing Specification

The Dayton Superior DBDI Splice System, consisting of the Dowel Bar and Dowel-In, shall be used in splicing of rebar. The DBDI System shall be forged from deformed rebar material, free of external welding and machining. It shall be furnished with an integral nailing flange and threaded with UNC or UN thread to a depth, at minimum, equal to the nominal thread diameter. The Dowel-In shall be fabricated from deformed rebar material with thread corresponding to the Splicer. The completed splice shall meet Type 2 tensile requirements of American Concrete Institute Specification 318 and Building Code Requirements for Reinforced Concrete

Specific:

- Mechanical connections shall be the DBDI® Splice System as manufactured by Dayton Superior Corporation.

Generic:

- The mechanical connection shall meet building code requirements of developing in tension and compression as required by _____ (insert name here). The mechanical connection shall be the forged and parallel threaded type coupler manufactured from high quality steel. All couplers shall be installed per the manufacturer’s approved procedures.

Recommended Dowel Bar and Dowel-In Sizes

Specified or Required Dowel Bar					Recommended Dowel Bar Splicer and Dowel-In						
Bar Size			Grade 60 Rebar Loads (lbs.)		System Thread Size*	DB Bar Size	DI Bar Size	System Stress Area (min.)	Completed Splice (lbs.)		
US	Metric (mm)	CN (M)	P _y	1.25 P _y					P _y	1.25 P _y	100% P _u
#4	[13]	[10]	12,000	15,000	5/8" - 11	#4	#4	.20	12,000	15,000	18,000
#5	[16]	[15]	18,600	23,250	3/4" - 10	#5	#5	.31	18,600	23,250	27,900
#6	[19]	[20]	26,400	33,000	7/8" - 9	#6	#6	.44	26,400	33,000	39,600
#7	[22]	—	36,000	45,000	1" - 8	#7	#7	.60	36,000	45,000	54,000
#8	[25]	[25]	47,400	59,250	1-1/8" - 8	#8	#8	.79	47,400	59,250	71,100
#9	[29]	[30]	60,000	75,000	1-1/4" - 8	#9	#9	1.00	60,000	75,000	90,000
#10	[32]	—	76,200	95,250	1-7/16" - 8	#10	#10	1.27	76,200	95,250	114,000
#11	[36]	[35]	93,600	117,000	1-9/16" - 8	#11	#11	1.56	93,600	117,000	140,400

P_y=Minimum Yield Strength of bar.

P_u=Minimum Tensile Strength of bar.

*5/8", 3/4", 7/8" and 1" sizes have UNC Threads. 1-1/8" and larger sizes are equipped with UN Threads.

Required Development and Lap Lengths for Grade 60, Uncoated Bottom Reinforcement in Normal Weight Concrete

Application	f' _c psi	#6 and Smaller Bars	#7 and Larger Bars
Clear spacing of bars being developed or spliced not less than d _b , clear cover not less than d _b , and beam stirrups or column ties throughout ℓ _d not less than the code minimum or Clear spacing of bars being developed or spliced not less than 2d _b and clear cover not less than d _b	3,000	44d _b	55d _b
	4,000	38d _b	47d _b
	5,000	34d _b	42d _b
	6,000	31d _b	39d _b
	8,000	27d _b	34d _b
	10,000	24d _b	30d _b
Other cases	3,000	66d _b	82d _b
	4,000	57d _b	71d _b
	5,000	51d _b	64d _b
	6,000	46d _b	58d _b
	8,000	40d _b	50d _b
	10,000	36d _b	44d _b

Typical Threaded Splicing Applications

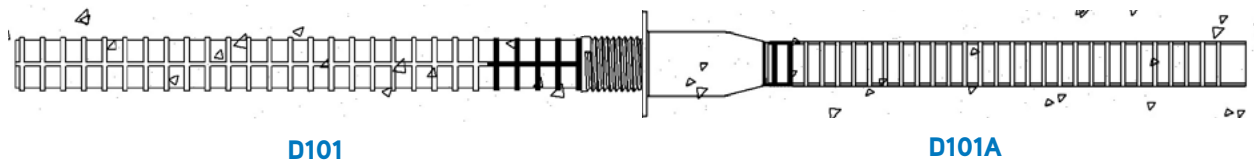

DBDI Splice System

D101 Dowel-In, D102 90° Hooked Dowel-In, D103 180° Hooked Dowel-In, D104 Double-Ended Dowel-In

The Dayton Superior Dowel-In is available Straight (D101), 90° and 180° Hooked (D102 and D103) and Double-Ended (D104). Each is manufactured from deformed rebar material and is available in rebar sizes #4 through #11. The threaded end of the Dowel-In is enlarged by forging, before threading, to ensure that the cross-sectional area of the bar is not reduced by the threading operation. This design feature assures full ultimate strength of the rebar. Dowel-Ins are configured to facilitate easy installation and can be easily assembled by hand. On larger projects, such as highway paving, a centrifugal chuck on an electric or air-powered drill motor can be employed to speed installation.

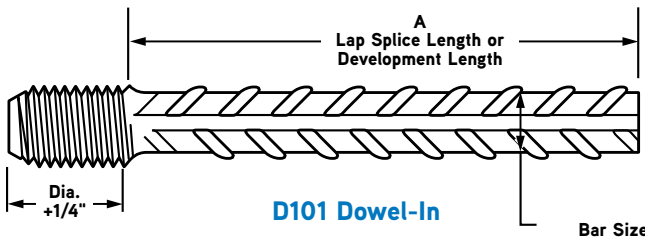

To Order:

Specify: (1) quantity, (2) name, (3) bar size (should be equivalent to the rebar being substituted for on the structural drawings), (4) dimensions required (see below).

Example:

600, D102 90° Hooked Dowel-Ins, #5 rebar, A=14", B=8"

Specified or Required Dowel Bar					Recommended Dowel Bar and Dowel-In							
Bar Size			Grade 60 Rebar Loads (lbs.)		System Thread Size*	DB Bar Size	DI Bar Size	System Stress Area (min.)	Completed Splice (lbs.)			
US	Metric (mm)	CN (M)	P _y	1.25 P _y					P _y	1.25 P _y	100% P _{ult}	
#4	[13]	[10]	12,000	15,000	5/8" - 11	#4	#4	.20	12,000	15,000	18,000	
#5	[16]	[15]	18,600	23,250	3/4" - 10	#5	#5	.31	18,600	23,250	27,900	
#6	[19]	[20]	26,400	33,000	7/8" - 9	#6	#6	.44	26,400	33,000	39,600	
#7	[22]	—	36,000	45,000	1" - 8	#7	#7	.60	36,000	45,000	54,000	
#8	[25]	[25]	47,400	59,250	1-1/8" - 8	#8	#8	.79	47,400	59,250	71,100	
#9	[29]	[30]	60,000	75,000	1-1/4" - 8	#9	#9	1.00	60,000	75,000	90,000	
#10	[32]	—	76,200	95,250	1-7/16" - 8	#10	#10	1.27	76,200	95,250	114,000	
#11	[36]	[35]	93,600	117,000	1-9/16" - 8	#11	#11	1.56	93,600	117,000	140,400	

P_y = Minimum Yield Strength of bar.

P_u = Minimum Tensile Strength of bar.

*5/8", 3/4", 7/8" and 1" sizes have UNC Threads. 1-1/8" and larger sizes are equipped with UN Threads.

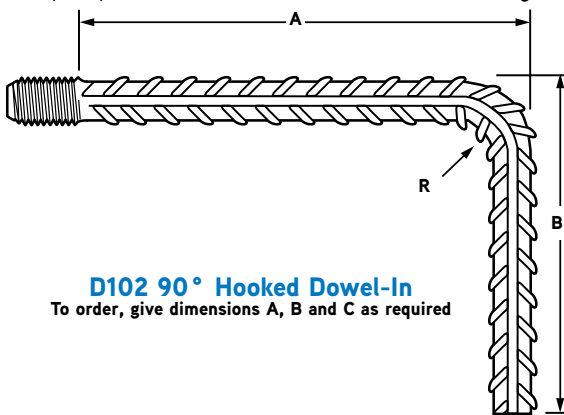

D102 90° Hooked Dowel-In

To order, give dimensions A, B and C as required

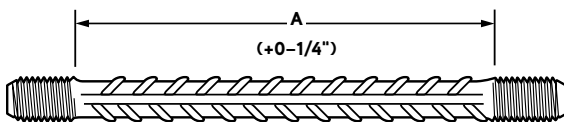

D104 Double-Ended Dowel-In

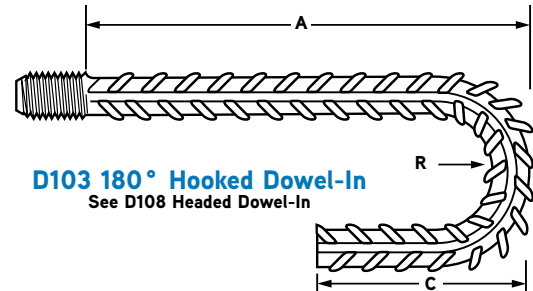

D103 180° Hooked Dowel-In

See D108 Headed Dowel-In

Bar Size Designation			D101 Minimum Mfg. Length DI DOWEL INS	D102/D103 Minimum Mfg. Length	D104 Minimum Length Double End Dowel Ins.
US	Metric (mm)	CN (M)			
#4	[13]	[10]	9"	4" *	8" **
#5	[16]	[15]	9"	5" *	8" **
#6	[19]	[20]	9-1/4"	6" *	8" **
#7	[22]	—	9-1/4"	7" *	8" **
#8	[25]	[25]	15-1/2"	8" *	14" **
#9	[29]	[30]	15-1/2"	9" *	14" **
#10	[32]	—	15-3/4"	10" *	14" **
#11	[36]	[35]	16"	11" *	14" **

NOTE: To be manufactured as Single End

* Tolerance on Bending Plus 0/ Minus 1" on "A" Dim.

** Plus thread each end.

DBDI Splice System

D101A Dowel Bar, D102A 90° Hooked Dowel Bar, D103A 180° Hooked Dowel Bar, D104A Double-Ended Dowel Bar

The Dayton Superior Dowel Bar is a one-piece unit, integrally forged from deformed rebar material. The splicers are available in #4 through #11 rebar sizes to be used in conjunction with the corresponding size Dowel-In to accomplish a mechanical splice designed to achieve full mechanical ultimate.

The splicer can be furnished straight (D101A) cut to length, 90° and 180° hooked (D102A and D103A) and double-ended (D104A). The splicer can also be special-ordered with a reduced diameter washer flange or with the washer flange clipped (in more than one direction, if required) to provide adequate concrete cover, or to avoid interference.

The D104A Double-Ended Dowel Bar is used to establish a direct load path through a concrete section, thus avoiding multiple hooked rebar and eliminating rebar congestion. The double-ended unit can be configured in a "U" shape for special applications.

Bar Size Designation			Thread Size	A	B	C	D	E	Flange Diameter	100% P _u
US	Metric (mm)	CN (M)								
#4	[13]	[10]	5/8" - 11 UNC	1-1/16"	1/8"	11/16"	55/64"	1"	1-7/8"	18,000
#5	[16]	[15]	3/4" - 10 UNC	1-9/16"	1/8"	13/16"	1-3/64"	1-1/8"	2-1/16"	27,900
#6	[19]	[20]	7/8" - 9 UNC	1-11/16"	1/8"	15/16"	1-15/64"	1-1/4"	2-1/4"	39,600
#7	[22]	-	1" - 8 UNC	1-27/32"	1/8"	1-1/16"	1-27/64"	1-3/8"	2-7/16"	54,000
#8	[25]	[25]	1-1/8" - 8 UN	2-1/16"	1/8"	1-3/16"	1-19/32"	1-1/2"	2-5/8"	71,100
#9	[29]	[30]	1-1/4" - 8 UN	2-3/16"	1/8"	1-5/16"	1-25/32"	1-5/8"	2-13/16"	90,000
#10	[32]	-	1-7/16" - 8 UN	2-7/16"	1/8"	1-1/2"	2"	1-13/16"	3"	114,000
#11	[36]	[35]	1-9/16" - 8 UN	2-9/16"	1/8"	1-5/8"	2-7/32"	1-15/16"	3-1/4"	140,400

P_u = Minimum Tensile Strength of bar.

Bar Size Designation			D101A
US	Metric (mm)	CN (M)	Minimum MFG. Length DB-SAE
#4	[13]	[10]	12"
#5	[16]	[15]	14"
#6	[19]	[20]	16"
#7	[22]	-	16"
#8	[25]	[25]	16"
#9	[29]	[30]	16"
#10	[32]	-	16"
#11	[36]	[35]	16"

NOTE: To be manufactured as Single End

NOTE: No. 4, 5 and 6 splicers, 18", 24" and 36" long will usually have a stamped metal plug to protect threads; all other sizes will have a plastic cap plug.

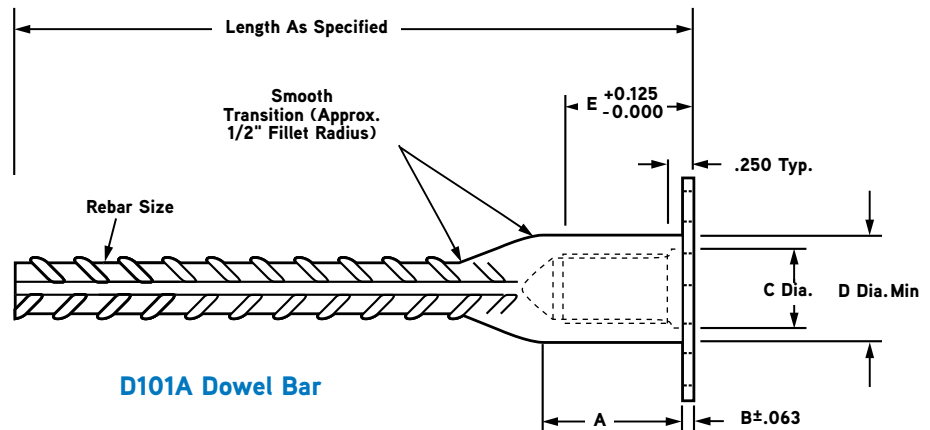

D101A Dowel Bar

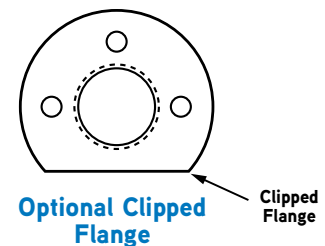
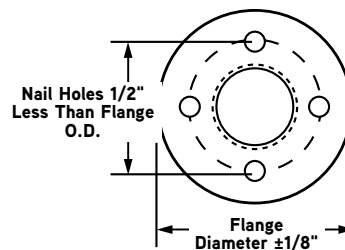

Recommended Dowel Bar and Dowel-In Sizes

Specified or Required Dowel Bar					Recommended Dowel Bar Splicer and Dowel-In							
Bar Size			Grade 60 Rebar Loads (lbs.)		System Thread Size*	DB-SAE Bar Size	Dowel-In Bar Size	System Stress Area (min.)	Completed Splice (lbs.)			
US	Metric (mm)	CN (M)	P _y	1.25 P _y					P _y	1.25 P _y	100% P _u	
#4	[13]	[10]	12,000	15,000	5/8" - 11	#4	#4	.20	12,000	15,000	18,000	
#5	[16]	[15]	18,600	23,250	3/4" - 10	#5	#5	.31	18,600	23,250	27,900	
#6	[19]	[20]	26,400	33,000	7/8" - 9	#6	#6	.44	26,400	33,000	39,600	
#7	[22]	—	36,000	45,000	1" - 8	#7	#7	.60	36,000	45,000	54,000	
#8	[25]	[25]	47,400	59,250	1-1/8" - 8	#8	#8	.79	47,400	59,250	71,100	
#9	[29]	[30]	60,000	75,000	1-1/4" - 8	#9	#9	1.00	60,000	75,000	90,000	
#10	[32]	—	76,200	95,250	1-7/16" - 8	#10	#10	1.27	76,200	95,250	114,000	
#11	[36]	[35]	93,600	117,000	1-9/16" - 8	#11	#11	1.56	93,600	117,000	140,400	

P_y = Minimum Yield Strength of bar.

P_u = Minimum Tensile Strength of bar.

*5/8", 3/4", 7/8" and 1" sizes have UNC Threads. 1-1/8" and larger sizes are equipped with UN Threads.

Bar Size Designation			Bending DB or DI 90° only Minimum "A" Dimension
US	Metric (mm)	CN (M)	
#4	[13]	[10]	4" *
#5	[16]	[15]	5" *
#6	[19]	[20]	6" *
#7	[22]	—	7" *
#8	[25]	[25]	8" *
#9	[29]	[30]	9" *
#10	[32]	—	10" *
#11	[36]	[35]	11" *

* Tolerance on Bending Plus 0 / Minus 1" on "A" Dimension

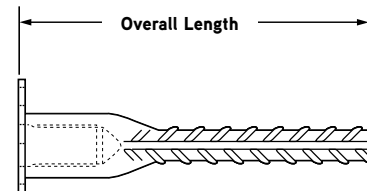
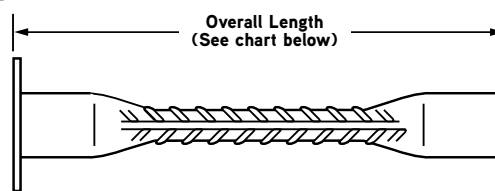
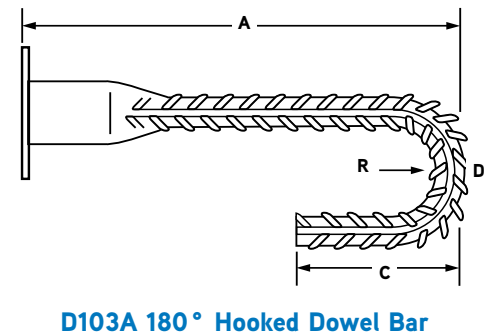
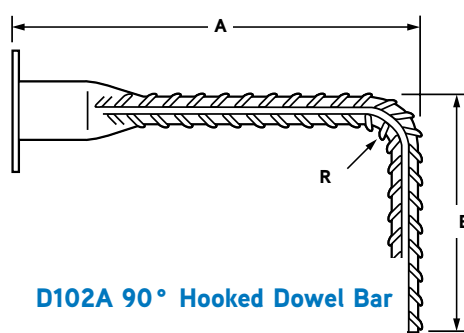

Bar Size Designation			D104A Double-Ended Min. Lengths	Tolerance Overall Length
US	Metric (mm)	CN (M)		
#4	[13]	[10]	13" O.A.	+0 - 3/8"
#5	[16]	[15]	13" O.A.	+0 - 3/8"
#6	[19]	[20]	14" O.A.	+0 - 1/2"
#7	[22]	—	16" O.A.	+0 - 5/8"
#8	[25]	[25]	16" O.A.	+0 - 3/4"
#9	[29]	[30]	16" O.A.	+0 - 1"
#10	[32]	—	16" O.A.	+0 - 1"
#11	[36]	[35]	16" O.A.	+0 - 1"

** Based on barrels forged on each end. For lengths less than minimum, please check with manufacturing facility. We may supply forged DB one end, DI with Coupler and nailer washer other end.

See D108 Headed Dowel Bar.

To Order:

Specify: (1) quantity, (2) name, (3) bar size (should be equivalent to the rebar being substituted for on the structural drawings), (4) dimensions required.

Example:

600, D101A Dowel Bars, #5 rebar, 36" long.

Typical DBDI Installation

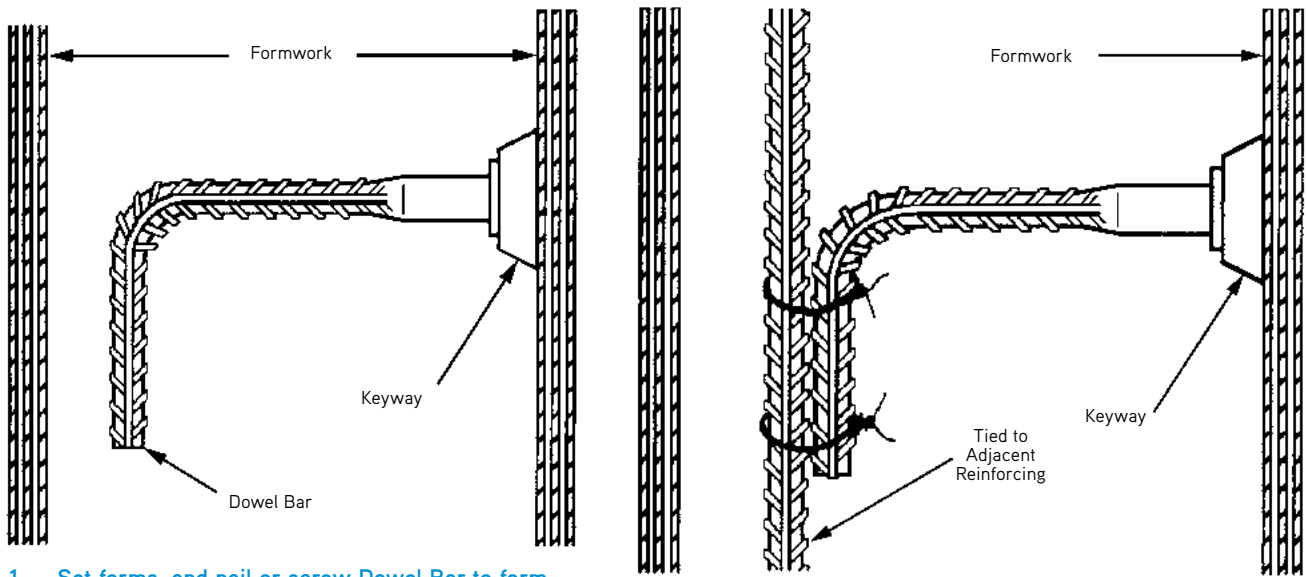

1. Set forms, and nail or screw Dowel Bar to form key.

2. Place required reinforcing steel.

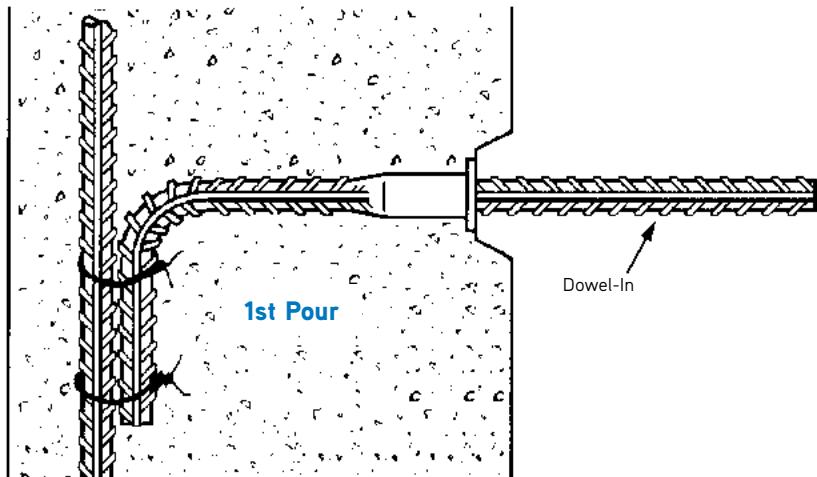

3. After first pour has properly set, remove the formwork and screw Dowel-Ins into the exposed Dowel Bars.

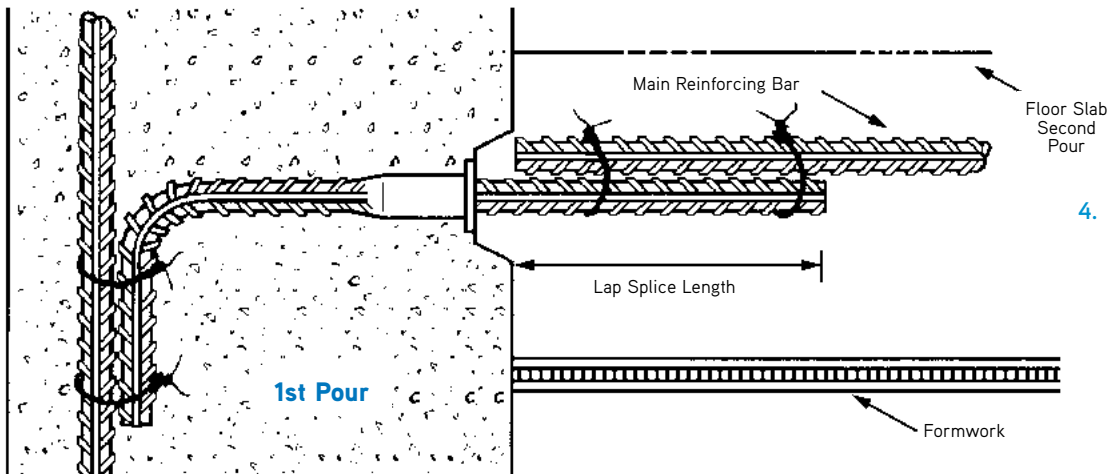

4. Place second pour formwork and reinforcing steel.

D106 DBDI Weldable Coupler

Product Description:

The D106 Weldable Couplers provide a convenient means of connecting reinforcing bars to structural steel plates or sections. Shorter than the standard coupler, it is threaded at one end. The other end is welded directly to the steel.

The couplers are produced using ASTM A108 or C 1018 steel

The D108 DBDI Weldable Coupler is suitable for welding to structural steels. The load conditions at the connection must be determined by the engineer along with the type and size of weld required. Another important consideration is the type of electrode to be used, which must be matched to the properties of the plate and tube, and to the site conditions under which the welding will be undertaken. Welders should be qualified for the type of weld required.



Product Features and Benefits:

- The compact design of the coupler ensures suitability for use in confined situations where space is restricted or where the loss of cover must be minimized
- Reduces engineering design time
- Eliminates rebar congestion
- Provides Type 2 splicing capacities and simplifies load paths
- Complies with ACI, Caltrans, IBC, and Ministries of Transportation for Ontario and Quebec
- Approved for use in fatigue applications

Product Specifications:

- Extension of DBDI product line
- Accommodates rebar sizes #4 through #11
- Type 2 Splice

To Order:

Specify: (1) quantity, (2) name, (3) rebar size.

Example:

500 pcs., D106 DBDI Weldable Coupler, #6.

Product Codes D106DBDI Weldable Coupler

Bar Size			Black (Made in USA)	Thickness (in.)	Outer Diameter (in.)	20° Chamfer (in.)
US	Metric (MM)	CN (M)				
#4	[13]	[10]	77714	1.125	1.3	0.25
#5	[16]	[15]	77715	1.25	1.3	0.25
#6	[19]	[20]	77716	1.375	1.3	0.38
#7	[22]	—	77717	1.5	1.5	0.38
#8	[25]	[25]	77718	1.625	1.6	0.50
#9	[29]	[30]	77719	1.75	1.9	0.56
#10	[32]	—	77720	1.9375	2.3	0.63
#11	[36]	[35]	77721	2.0625	2.4	0.75

D50 DBR Coupler System

The DBR Couplers and DBR Setting/Splice Bars are simple, easy to use and familiar to all construction workers. The coupler is fastened to the formwork by nails, screws or a NC threaded bolt of proper diameter and length. The D50 DBR Coupler splice meets or exceeds codes requiring Type 1.

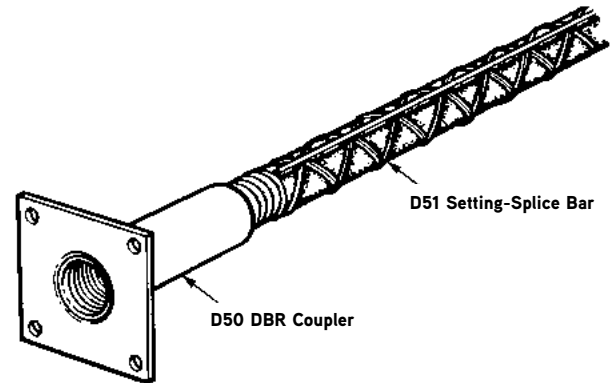

D50 DBR Coupler and DBR Setting/Splice Bars

The Dayton Superior D50 DBR Coupler is fabricated from high quality steel satisfying ASTM A-108 and is tested in accordance with ACI, AASHTO and ASTM standards. DBR Couplers accommodate rebar sizes #4 through #11 and have an internal positive stop to ensure proper thread engagement. Refer to tables for additional specifications.

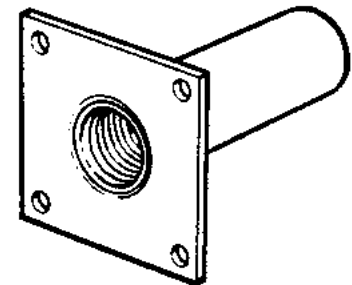

D50 DBR Coupler

2" x 2" washer for DBR Bar Size #4 through #9, 3" x 3" washer for DBR Bar Size #10 and 11.

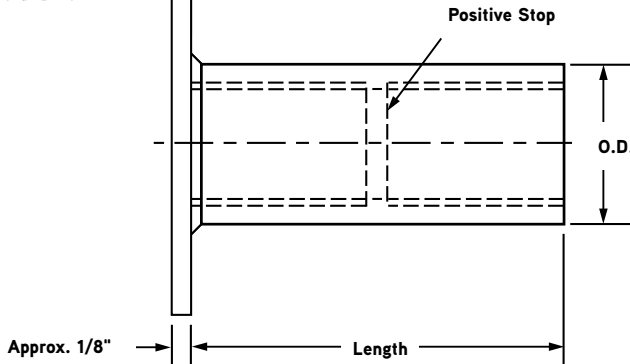

To Order:
Specify: (1) quantity, (2) name, (3) rebar size
Example:
500 pcs., D50 DBR Couplers, #8 rebar.

D50 DBR Coupler Selection Chart

Product Code	Bar Size Designation			Thread Data	O.D. x Length
	US	Metric (mm)	CN (M)		
77098	#4	[13]	[10]	1/2" - 13 UNC	3/4" x 1-7/8"
77100	#5	[16]	[15]	5/8" - 11 UNC	7/8" x 2"
77110	#6	[19]	[20]	3/4" - 10 UNC	1-1/16" x 2-3/8"
77120	#7	[22]	—	7/8" - 9 UNC	1-1/4" x 2-3/4"
77130	#8	[25]	[25]	1" - 8 UNC	1-3/8" x 3-1/8"
77140	#9	[29]	[30]	1-1/8" - 8 UN	1-5/8" x 3-5/8"
77142	#10	[32]	—	1-1/4" - 8 UN	1-3/4" x 4-1/8"
77144	#11	[36]	[35]	1-3/8" - 8 UN	1-15/16" x 4-3/8"

Note: Threads on #9, #10 and #11 couplers are UN not NC.

D51 DBR Straight Bar Threaded One End

D51 Straight Bar Selection Chart

Bar Size Designation			Thread Data	Thread Engagement
US	Metric (mm)	CN (M)		
#4	[13]	[10]	1/2" - 13 UNC	3/4"
#5	[16]	[15]	5/8" - 11 UNC	7/8"
#6	[19]	[20]	3/4" - 10 UNC	1-1/16"
#7	[22]	—	7/8" - 9 UNC	1-1/4"
#8	[25]	[25]	1" - 8 UNC	1-7/16"
#9	[29]	[30]	1-1/8" - 8 UN	1-11/16"
#10	[32]	—	1-1/4" - 8 UN	1-15/16"
#11	[36]	[35]	1-3/8" - 8 UN	2-1/16"

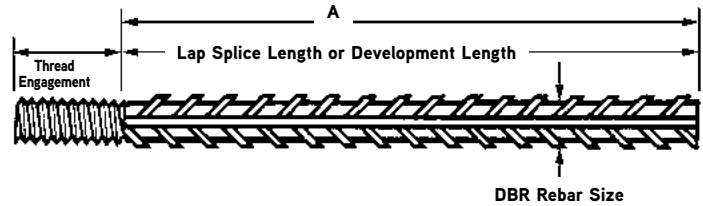

D54 DBR Straight Bar Threaded Both Ends

Note: Color coded removable plastic caps available on request.

D51 overall length is required length less one half of coupler length.

D54 overall length is required length less coupler length minus 5/16".

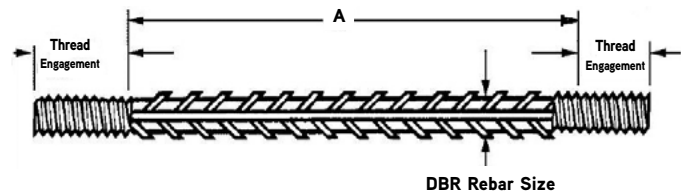

D52 DBR 90° Hook Bar and D53 180° Hook Bar Threaded One End

D52 and D53 Hook Bar Selection Chart

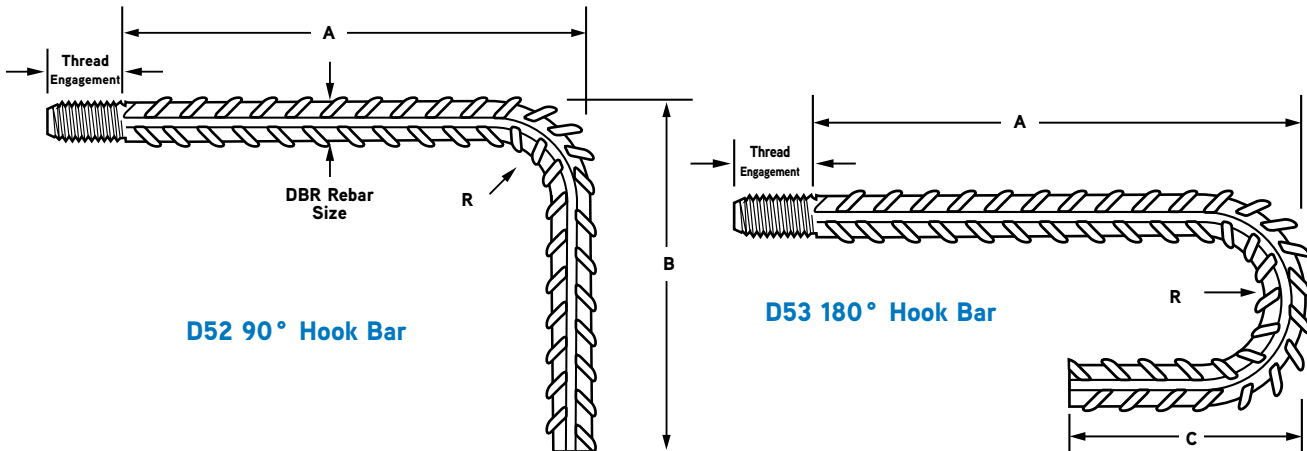

Bar Size Designation			Thread Data	Thread Engagement	A* Standard For D52	A Standard For D53	B Standard For D52	C Standard For D53	R Standard
US	Metric (mm)	CN (M)							
#4	[13]	[10]	1/2" - 13 UNC	3/4"	4-1/2"	9-3/4"	8"	4-1/2"	1-1/2"
#5	[16]	[15]	5/8" - 11 UNC	7/8"	5-1/2"	12"	10"	5"	1-7/8"
#6	[19]	[20]	3/4" - 10 UNC	1-1/16"	7"	23"	12"	6"	2-1/4"
#7	[22]	—	7/8" - 9 UNC	1-1/4"	8"	24"	14"	7"	2-5/8"
#8	[25]	[25]	1" - 8 UNC	1-7/16"	9"	25"	16"	8"	3"
#9	[29]	[30]	1-1/8" - 8 UN	1-11/16"	11"	31"	19-3/8"	10-3/8"	4-3/4"
#10	[32]	—	1-1/4" - 8 UN	1-15/16"	12"	32"		11-5/8"	5-3/8"
#11	[36]	[35]	1-3/8" - 8 UN	2-1/16"	14"	33"	23-7/8"	12-7/8"	6"

To Order:

Specify: (1) quantity, (2) name, (3) bar size (4) dimension "A" (as specified on plans) (5) dimension "B" or "C" and (6) dimension "R"

Example:

500 pcs., D52 90° Hook Bar, #6, A=7", B=20", R=2"

Notes: Color coded removable plastic caps available on request.

* Based on "R" minimum as shown. Standard dimensions are to CRSI standard by pin size.

D51A DBR Straight Bar Threaded One End

D51A Straight Bar Selection Chart

Bar Size Designation			Thread Data	A Thread Engagement
US	Metric (mm)	CN (M)		
#4	[13]	[10]	1/2" - 13 UNC	3/4"
#5	[16]	[15]	5/8" - 11 UNC	7/8"
#6	[19]	[20]	3/4" - 10 UNC	1-1/16"
#7	[22]	—	7/8" - 9 UNC	1-1/4"
#8	[25]	[25]	1" - 8 UNC	1-7/16"
#9	[29]	[30]	1-1/8" - 8 UN	1-11/16"
#10	[32]	—	1-1/4" - 8 UN	1-15/16"
#11	[36]	[35]	1-3/8" - 8 UN	2-1/16"

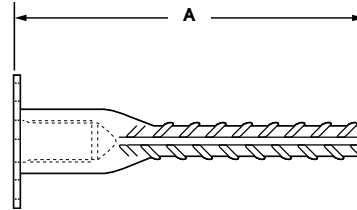

D51A Dowel Bar Splicer

D54A DBR Straight Bar Threaded Both Ends

Note: Color coded removable plastic caps available on request.

D51A overall length is required length less one half of coupler length.

D54A overall length is required length less coupler length minus 5/16".

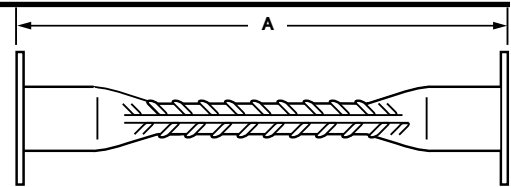

D54A Double-Ended Dowel Bar Splicer

D52A DBR 90° Hook Bar and D53A 180° Hook Bar Threaded One End

D52A and D53A Hook Bar Selection Chart

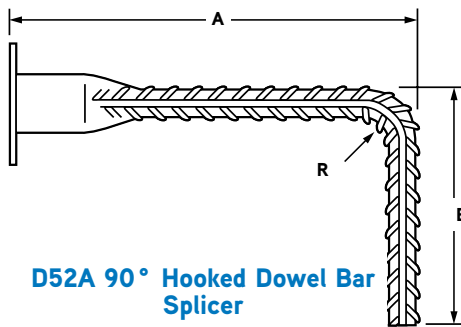

D52A 90° Hooked Dowel Bar Splicer

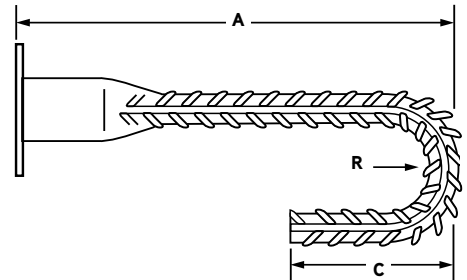

D53A 180° Hooked Dowel Bar Splicer

Bar Size Designation			Thread Data	Thread Engagement	B* Standard For D52A	B Standard For D53A	B Standard For D52A	D Standard For D53A	R Standard
US	Metric (mm)	CN (M)							
#4	[13]	[10]	1/2" - 13 UNC	3/4"	4-1/2"	9-3/4"	8"	4-1/2"	1-1/2"
#5	[16]	[15]	5/8" - 11 UNC	7/8"	5-1/2"	12"	10"	5"	1-7/8"
#6	[19]	[20]	3/4" - 10 UNC	1-1/16"	7"	23"	12"	6"	2-1/4"
#7	[22]	—	7/8" - 9 UNC	1-1/4"	8"	24"	14"	7"	2-5/8"
#8	[25]	[25]	1" - 8 UNC	1-7/16"	9"	25"	16"	8"	3"
#9	[29]	[30]	1-1/8" - 8 UN	1-11/16"	11"	31"	19-3/8"	10-3/8"	4-3/4"
#10	[32]	—	1-1/4" - 8 UN	1-15/16"	12"	32"	21-9/16"	11-5/8"	5-3/8"
#11	[36]	[35]	1-3/8" - 8 UN	2-1/16"	14"	33"	23-7/8"	12-7/8"	6"

Notes: Color coded removable plastic caps available on request.

* Based on "R" minimum as shown. Standard dimensions are to CRSI standard by pin size.

To Order:

Specify: (1) quantity, (2) name, (3) bar size (4) dimension "B" (as specified on plans) (5) dimension "C" or "D" and (6) dimension "R"

Example:

500 pcs., D52A 90° Hook Bar, #6, A=7", B=20", R=2"

Bar Size Designation			Reinforcing Bar Area (in ²)	Minimum Yield (lbs)	Minimum Ultimate (lbs)	Thread Data	Thread Data		
US	Metric (mm)	CN (M)					Thread Tensile Stress Area (in ²)	125% f _y Min. Requirements (lbs)	Minimum Ultimate Tensile Stress (psi)
#4	[13]	[10]	0.20	12,000	18,000	1/2"-13 NC	0.1419	15,000	105,708
#5	[16]	[15]	0.31	18,600	27,900	5/8"-11 NC	0.226	26,250	102,876
#6	[19]	[20]	0.44	26,400	39,600	3/4"-10 NC	0.334	33,000	98,802
#7	[22]	—	0.60	36,000	54,000	7/8"-9 NC	0.462	45,000	97,403
#8	[25]	[25]	0.79	47,400	71,100	1"-8 UNC	0.606	59,250	97,772
#9	[29]	[30]	1.00	60,000	90,000	1-1/8"-8 UN	0.790	75,000	94,937
#10	[32]	—	1.27	76,200	114,300	1-1/4"-8 UN	1.000	95,250	95,250
#11	[36]	[35]	1.56	93,600	140,400	1-3/8"-8 UN	1.233	117,000	94,891

How to Install the DBR Coupler System

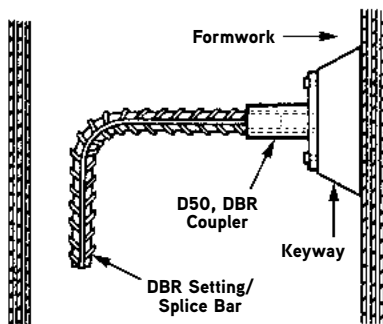

Step 1

A DBR Setting/Splice Bar is threaded into the D50 coupler until the positive thread stop is reached. The D50 DBR coupler is then fastened to the formwork with nails, screws or bolts.

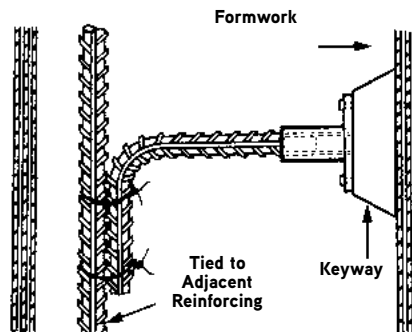

Step 2

The DBR Setting/Splice Bar is tied off to adjacent reinforcing steel, for proper support during concrete placement as well as to maintain the required lap splice length.

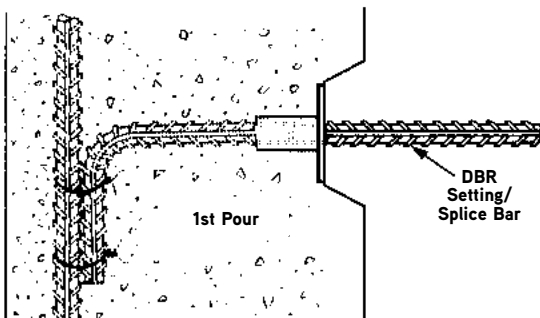

Step 3

After the formwork is stripped, a second DBR Setting/Splice Bar is threaded into the exposed end of the D50 coupler until the stop is reached.

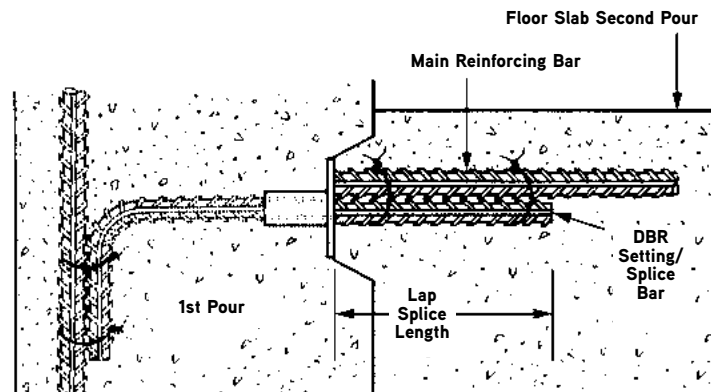

Step 4

The DBR Setting/Splice bar is tied to the adjacent reinforcing steel maintaining the proper lap splice length. The dowel bar replacement is now complete, ready for final concrete placement.

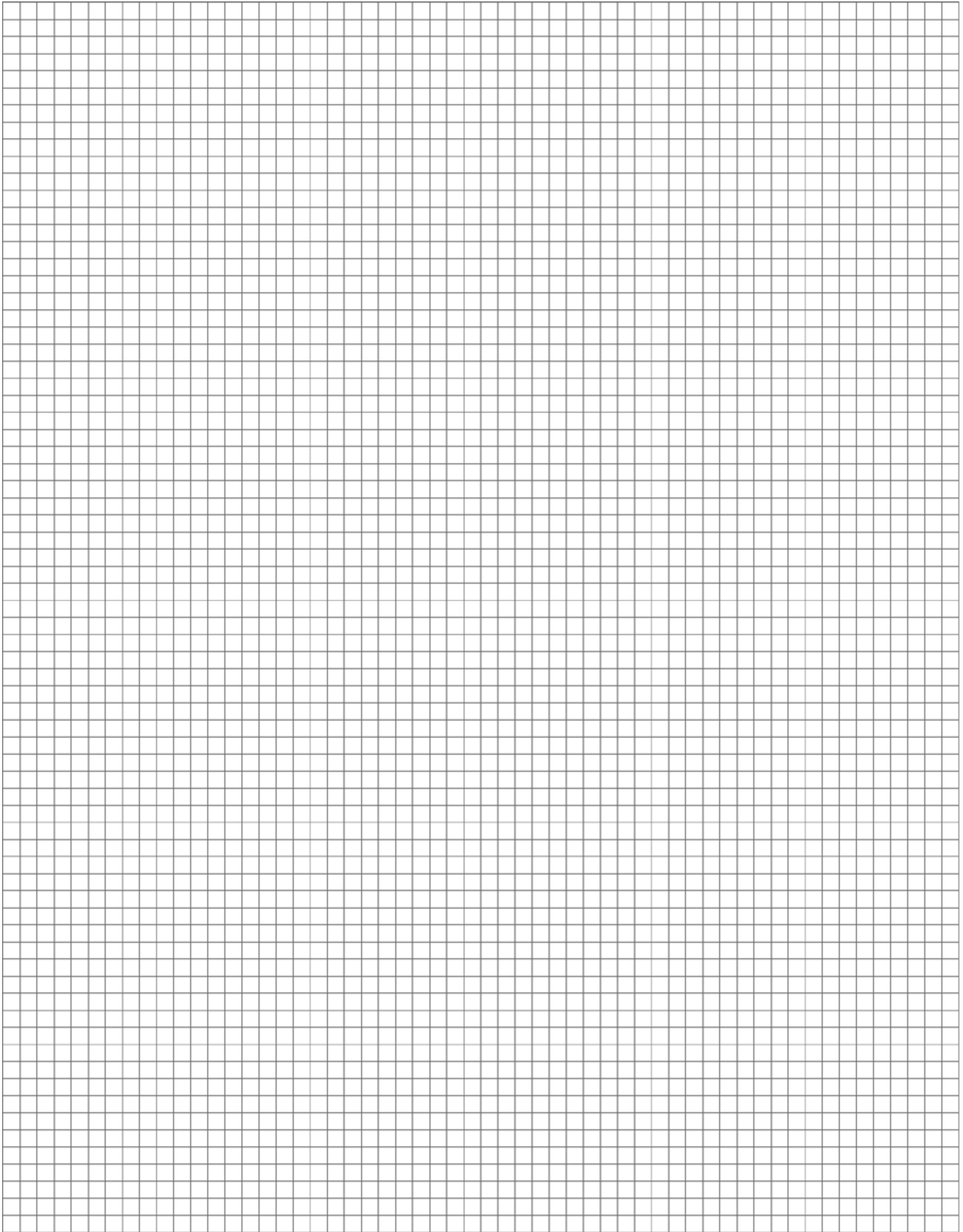

Dayton Superior Bar Lock® Coupler System

IAPMO UES Listed ER-319

The Dayton Superior Bar Lock Coupler System provides a simple, quick, cost effective method for splicing rebar in tension and/or compression applications. Bar Lock Couplers may be used with plain or epoxy coated rebars in sizes #4 through #18.

Bar Lock Couplers utilize lock-shear bolts and special grip rails to mechanically splice the rebar. The serrated grip rails cradle the rebar and are embedded in the rebar as the lock-shear bolts are tightened. The heads of the lock-shear bolts are designed to shear off at a prescribed torque in order to accomplish proper installation.

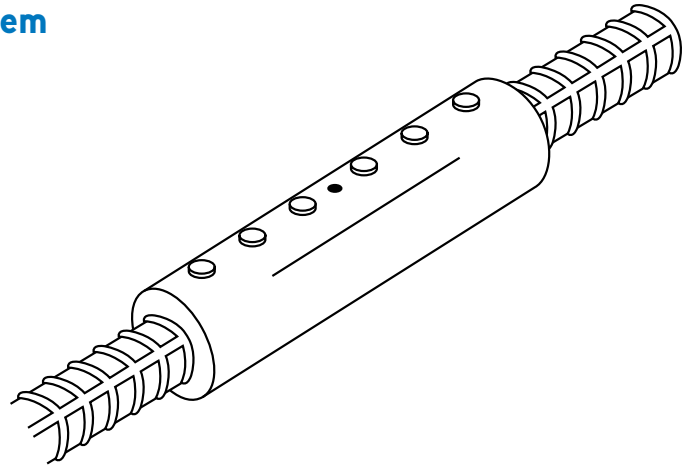

Typical Bar Lock Coupler System Splice
U.S. Patent No. 4,666,326 and 5,046,878

System Advantages:

- Quick and easy to install – saves time and money.
- Eliminates bar threading and/or special bar end treatment.
- No special installation equipment required.
- High strength in tension, compression and seismic applications.
- Available in standard, transition and weldable end anchor versions in #4 through #18 sizes.
- Ideal for new construction and rehab projects.

System Compliance

Bar Lock Couplers are test-certified to exceed the requirements of, are pre-qualified and approved, or recognized by the following building approval agencies:

- State Departments of Transportation
- International Code Council (ICC)
- International Building Code (IBC)
- American Concrete Institute (ACI)
- Concrete Reinforcing Steel Institute (CRSI)
- City of Los Angeles Department of Building and Safety

Bar Lock Coupler source material is fabricated under ISO 9000 quality standards. Bar Lock couplers are tested by independent, certified testing laboratories in four modes of testing: tension, compression, fatigue and cyclic. All tests are done to the requirements of IAPMO and/or Caltrans requirements utilizing ASTM A615 and A706 grade 60, 75, and 80.

Typical Specification

Specific:

- Mechanical connections shall be Bar Lock® lockshear bolt couplers as manufactured by Dayton Superior Corporation.

Generic:

- The mechanical connection shall meet building code requirements of developing in tension and compression as required by _____ (insert name here). The mechanical connection shall be the positive butt splices utilizing lock shear bolts and internal serrated grip rails within the coupling sleeve manufactured from high quality steel. All couplers shall be installed per the manufacturer's approved procedures.



D250SCA Bar Lock® S/CA-Series Couplers

The D250SCA Bar Lock S/CA-Series Couplers are designed for use in most tension and compression applications. They are available in rebar sizes #4 through #18 and exceed Type 1 performance. S/CA couplers are an approved Caltrans "Service" splice and are recognized by IAPMO UES, ACI and most State departments of Transportation. S/CA couplers are available in transition sizes, weldable half couplers. The D250SCA Bar Lock S/CA-Series Couplers are designed for use in most tension and compression applications. They are available in rebar sizes #4 through #18 and exceed Type 1 performance in accordance to ACI 318-17 and earlier code provisions. S/CA couplers are an approved Caltrans "Service" splice and are recognized by IAPMO UES, ACI and most State departments of Transportation. S/CA couplers are available in transition sizes, weldable half couplers. For use with Grade 60 Rebar. The S/CA coupler can also achieve a type 2 splice according to the strength requirements outlined in ACI 318-19 when used with plain #4 through #14 grade 60 rebar.

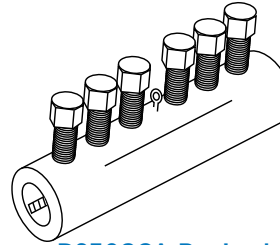

D250SCA Bar Lock S/CA-Series Coupler

To Order:
Specify: (1) quantity,
(2) name, (3) coupler
designation.

Example:
300, D250SCA Bar Lock®
S/CA-Series Couplers, 8S/
CA.

Product Code		Coupler Designation	Bar Size Designation			Barrel Stamp Identification	Product Specifications			Bolt Specifications			Meets or Exceeds		
Black	Epoxy		US	Metric (mm)	CN (M)		Outside Diameter (in.)	Length (in.)	Weight (lbs.)	Bolt Qty.	Head Size (in.)	Nominal Shear Torque*	Min % Fu**	CAL TRANS Service	ICC Type 1
400200	400210	3 S/CA	#3	[10]	—	3S...CA	1.3	3.9	1.24	4	0.5	40	125	YES	YES
400200	400210	4 S/CA	#4	[13]	[10]	4S...CA	1.3	3.9	1.24	4	0.5	40	125	YES	YES
400201	400211	5 S/CA	#5	[16]	[15]	5S...CA	1.7	4.5	2.11	4	0.5	80	125	YES	YES
400202	400212	6 S/CA	#6	[19]	[20]	6S...CA	1.9	6.3	3.57	6	0.5	80	125	YES	YES
400203	400213	7 S/CA	#7	[22]	—	7S...CA	1.9	8.0	4.30	8	0.5	80	125	YES	YES
400204	400214	8 S/CA	#8	[25]	[25]	8S...CA	2.4	10.2	6.10	8	0.625	180	125	YES	YES
400205	400215	9 S/CA	#9	[29]	[30]	9S...CA	2.9	9.0	11.88	6	0.75	350	125	YES	YES
400206	400216	10 S/CA	#10	[32]	—	10S...CA	2.9	11.5	15.17	8	0.75	415	125	YES	YES
400207	400217	11 S/CA	#11	[36]	[35]	11S...CA	3.1	14.0	20.50	10	0.75	415	125	YES	YES
400208	400218	14 S/CA	#14	[43]	[45]	14S...CA	3.5	19.1	31.75	14	0.75	475	125	YES	YES
400209	400219	18 S/CA	#18	[57]	[55]	18S...CA	4.3	27.2	62.00	20	0.75	475	125	YES	YES

Note in place of the "...", each Bar Lock Coupler is marked with a tracking code used for full manufacturing traceability.

* Foot pounds. ** When used in conjunction with epoxy-coated Grade 60 rebar, 125% Fy strength is developed.

D250L Bar Lock® L-Series Coupler

The D250L Bar Lock L-Series Coupler is similar to the Standard Coupler but is designed for higher loads, such as extreme tension/compression applications and/or seismic loading conditions. L-Series couplers are available in rebar sizes #4 through #18 and provide Type 2 performance for Grade 60, and Type 1 for Grade 75. L-Series couplers are approved for use by most state DOTs and meet ACI specifications.

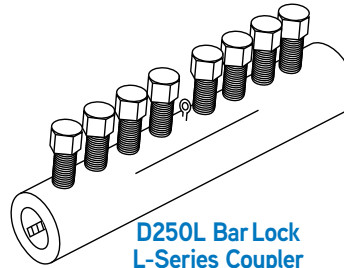

D250L Bar Lock L-Series Coupler

To Order:
Specify: (1) quantity,
(2) name,
(3) coupler designation,
(4) if epoxy coating is required.

Example:
100, D250L Bar Lock® L-Series
Couplers, 8L, epoxy coated.

Product Code		Coupler Designation	Bar Size Designation			Barrel Stamp Identification	Product Specifications			Bolt Specifications			Meets or Exceeds			
Black	Epoxy		US	Metric (mm)	CN (M)		Outside Diameter (in.)	Length (in.)	Weight (lbs.)	Bolt Qty.	Head Size (in.)	Nominal Shear Torque*	Min % Fu**	CAL TRANS Service	ICC Type 1	ICC Type 2
400327	144988	3 L	#3	[10]	—	3L...	1.3	4.0	1.67	4	0.5	40	100	YES	YES	YES
400226	400235	4 L	#4	[13]	[10]	4L...	1.3	5.5	1.67	6	0.5	40	100	YES	YES	YES
400227	400236	5 L	#5	[16]	[15]	5L...	1.7	6.3	2.90	6	0.5	80	100	YES	YES	YES
400228	400237	6 L	#6	[19]	[20]	6L...	1.9	8.0	4.44	8	0.5	80	100	YES	YES	YES
400229	400238	7 L	#7	[22]	—	7L...	1.9	9.8	5.10	10	0.5	80	100	YES	YES	YES
400230	400239	8 L	#8	[25]	[25]	8L...	2.4	12.3	8.94	10	0.625	180	100	YES	YES	YES
400231	400240	9 L	#9	[29]	[30]	9L...	2.9	11.5	15.07	8	0.75	350	100	YES	YES	YES
400232	400241	10 L	#10	[32]	—	10L...	2.9	14.0	18.50	10	0.75	415	100	YES	YES	YES
400233	400242	11 L	#11	[36]	[35]	11L...	3.1	16.5	23.75	12	0.75	415	100	YES	YES	YES
100521	—	12L	#12	[40]	—	12L...	3.1	16.5	23.75	12	0.75	415	100	YES	YES	YES
145831	145832	14 L	#14	[43]	[45]	14L...	3.5	21.58	35.14	16	0.75	475	100	YES	YES	YES
142996	142996	18 L	#18	[57]	[55]	18L...	4.3	32.2	97.80	24	0.75	475	100	YES	YES	YES

Note in place of the "...", each Bar Lock Coupler is marked with a tracking code used for full manufacturing traceability.

* Foot pounds. ** When used in conjunction with epoxy-coated Grade 60 rebar, 135% Fy strength is developed.

D250XL Bar Lock® XL-Series Coupler

The D250XL Bar Lock XL-Series Coupler is similar to the L-Series Coupler but is designed for higher loads and higher strength rebar. XL-Series couplers are available in rebar sizes #4 through #18 and exceed Type 2 performance. XL-Series Couplers are approved for use by most DOTs, are recognized as a Type 2 seismic splice, and meet ACI specifications. For use with Grades 60, 75, 80 rebar.

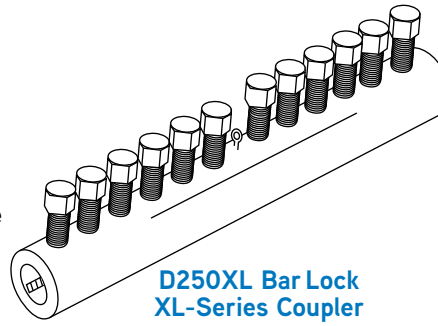

D250XL Bar Lock XL-Series Coupler

To Order:
Specify: (1) quantity, (2) name, (3) coupler designation, (4) if epoxy coating is required.

Example:
100, D250XL Bar Lock® XL-Series Couplers, 8XL, epoxy coated.

Product Code			Coupler Designation	Bar Size Designation			Barrel Stamp Identification	Product Specifications			Bolt Specifications			Meets or Exceeds			
Black	Epoxy	Galvanized		US	Metric (mm)	CN (M)		Outside Diameter (in.)	Length (in.)	Weight (lbs.)	Bolt Qty.	Head Size (in.)	Nominal Shear Torque*	Min % Fu**	CAL TRANS Service	ICC Type 1	ICC Type 2
145314	145324	145147	4 XL	#4	[13]	[10]	4XL....	1.3	10.2	3.10	12	0.5	40	100	YES	YES	YES
145315	145325	145148	5 XL	#5	[16]	[15]	5XL....	1.7	11.5	5.29	12	0.5	80	100	YES	YES	YES
145316	145326	145149	6 XL	#6	[19]	[20]	6XL....	1.9	13.2	7.33	14	0.5	80	100	YES	YES	YES
145317	145327	145150	7 XL	#7	[22]	—	7XL....	1.9	15.0	7.81	16	0.5	80	100	YES	YES	YES
145318	145328	145151	8 XL	#8	[25]	[25]	8XL....	2.4	18.7	13.59	16	0.625	180	100	YES	YES	YES
145319	145329	145152	9 XL	#9	[29]	[30]	9XL....	2.9	19.1	25.03	14	0.75	350	100	YES	YES	YES
145320	145330	145153	10 XL	#10	[32]	—	10XL....	2.9	21.6	28.54	16	0.75	415	100	YES	YES	YES
145321	145331	145154	11 XL	#11	[36]	[35]	11XL....	3.1	24.1	34.69	18	0.75	415	100	YES	YES	YES
145322	145332	145155	14 XL	#14	[43]	[45]	14XL....	3.5	29.1	48.14	22	0.75	475	100	YES	YES	YES
145323	145333	145156	18 XL	#18	[57]	[55]	18XL....	4.3	44.8	136.06	34	0.75	475	100	YES	YES	YES

Note in place of the "...", each Bar Lock Coupler is marked with a tracking code used for full manufacturing traceability.

* Foot pounds.

D220 Bar Lock® Transition Couplers

Bar Lock Transition Couplers are used to splice two rebar of different diameters. Transition Couplers are available in S/CA Series, L-Series, and XL-Series. Transition Couplers can be made any size combination.

All size combinations are limited by the capacity of the smaller rebar size. The S/CA series will develop an ACI 318 Type 1 grade 60 splice, the L-Series will develop an ACI 318 Type 2 grade 60 splice, and the XL-Series will develop an ACI 318 Type 2 grade 80 splice.

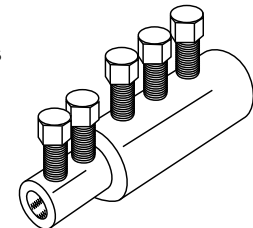

D220 Bar Lock Transition Coupler

Bar Size Designation			Side A (small side)				Side B (large side)				Total Length
US	Metric (mm)	CN (M)	Barrel Size	Length (in.)	Bolt Qty.	Head Size (In.)	Barrel Size	Length (in.)	Bolt Qty.	Head Size (In.)	
#4	[13]	[10]	#4	2.22	2	0.5	#5	2.53	2	0.5	4.75
#5	[16]	[15]	#6	3.15	2	0.5	#6	3.15	3	0.5	6.30
#6	[19]	[20]	#7	5.08	4	0.5	#8	5.08	4	0.625	10.16
#7	[22]	—	#8	5.33	4	0.625	#10	6.00	4	0.75	11.33
#8	[25]	[25]	#9	5.75	3	0.75	#10	5.75	4	0.75	11.50
#9	[29]	[30]	#11	7.01	3	0.75	#11	7.01	5	0.75	14.02
#10	[32]	—	#10	6.00	4	0.75	#14	8.52	6	0.75	14.52
#11	[36]	[35]	#11	7.26	5	0.75	#14	8.52	6	0.75	15.75
#14	[43]	[45]	#14	8.52	6	0.75	#18	13.83	10	0.75	22.35

To Order:
Specify: (1) quantity, (2) name, (3) transition size, (4) if epoxy coating is required.

Example:
100, D250 Bar Lock® Series Transition Couplers, #7-#8, epoxy coated.

This table lists commonly ordered transition sizes. Other sizes available. Transition Couplers are available in S/CA-Series (shown above) sizes #4-#18, L-Series in sizes #4-#18, and XL-Series in sizes #4-#18.

D251L Bar Lock® L-Series End Anchor

DESCRIPTION

The D251L Bar Lock End Anchor is a rebar end anchor used to provide anchorage. It consists of a thick walled tube, specially designed lock shear bolts, serrated grip rails, and a welded, headed disc. The D251L is made from USA melted and rolled steel.



To Order:
Specify: (1) quantity, (2) name, (3) bar size, (4) finish.

Example:
500, D251L Bar Lock® End Anchors, #18, Galvanized.

APPLICATION

The D251L Bar Lock End Anchor provides embedment anchorage.

PRODUCT SPECIFICATION

- Rebar sizes #4 (13mm) through #18 (57mm)
- Available in plain, epoxy coated, or galvanized finish
- Class A per ASTM A970
- IAPMO UES Listed ER-245 (#4-#14)

FEATURES

- Quick and easy installation
- No bar end preparation
- Installation at the job site
- Gross bearing area of 5Ab
- Anchor disk through hole permits offset installation in high congestions applications

BENEFITS

- Saves time and money
- No fabrication required
- One product for all applications

HOW TO SPECIFY

Specific:

Mechanical connections shall be Bar Lock® Rebar Splices as manufactured by Dayton Superior Corp.

Generic:

The mechanical connection shall meet building code requirements of developing in tension and compression as required by _____ (insert name here). The mechanical connection shall be made from lock shear bolt couplers with serrated gripping rails manufactured from high quality steel. All couplers shall be installed per the manufacturer's approved procedures.

TECHNICAL DATA

APPROVALS / COMPLIANCE

- ACI 318
- State Departments of Transportation
- AASHTO and International Building Code (IBC)



Size	Outside Dia. (barrel) in.	Outside Dia. (anchor) in.	Length (in.)	Bolt Qty.
#4 - 13MM	1.315	1.750	3.585	3
#5 - 16MM	1.661	2.000	4.025	3
#6 - 19MM	1.902	2.375	4.954	4
#7 - 22MM	1.900	2.875	5.882	5
#8 - 25MM	2.244	3.250	7.392	5
#9 - 29MM	2.898	3.625	7.188	4
#10 - 32MM	2.898	4.050	8.510	5
#11 - 36MM	3.118	4.500	9.830	6
#14 - 43MM	3.500	5.375	11.528	7
#18 - 57MM	4.290	7.250	17.875	12

INSTALLATION

1. Insert the end of the rebar halfway into the coupler until it bottoms against face of anchor.
2. Holding the rebar in place, tighten all the bolts until they are hand tight against the rebar.
3. In a random, alternating pattern, tighten all bolts to approximately 50%.
4. In a random, alternating pattern, tighten all bolts to approximately 75%.
5. In a random, alternating pattern, tighten all bolts until all the heads of the bolts shear off.

Note:

- A. Prior to bolt tightening, the serrated rails **MUST** remain aligned in the same position as they were manufactured. If they are damaged or knocked out of alignment while positioning, installation **MUST** cease and a new coupler used.
- B. Bolt tightening **MUST** be done in a random alternating pattern similar to tightening the lug nuts on an automobile wheel.
- C. A high-quality, 1" - pneumatic drive, impact wrench with at least 100 psig air flow and 185 CFM of delivered air through a no less than 0.75" hose **MUST** be used for installation.

RELATED PRODUCTS

- D250SCA Bar Lock® Couplers
- D250L Bar Lock® Couplers

ORDERING INFORMATION

BLACK (MADE IN USA)

Product Code	Description	Weight
400440	#4 - 13MM	2 LB
400441	#5 - 16MM	2.2 LB
400442	#6 - 19MM	3.4 LB
400443	#7 - 22MM	4.9 LB
400444	#8 - 25MM	7.4 LB
400445	#9 - 29MM	10.5 LB
400446	#10 - 32MM	13.5 LB
400447	#11 - 36MM	16.75 LB
400448	#14 - 43MM	27 LB
400449	#18 - 57MM	57 LB

D252L Bar Lock® L-Series End Anchor

DESCRIPTION

The D252L Bar Lock End Anchor is a rebar end anchor used to provide anchorage. It consists of a thick walled tube, specially designed lock shear bolts, serrated grip rails, and a welded, headed disc. The D252L is made from USA melted and rolled steel.



To Order:

Specify: (1) quantity, (2) name, (3) bar size, (4) finish.

Example:

500, D252L Bar Lock® End Anchors, #18, Galvanized.

APPLICATION

The D252L Bar Lock End Anchor is used to provide embedment anchorage.

PRODUCT SPECIFICATION

- Rebar sizes #4 (13mm) through #18 (57mm)
- Available in plain, epoxy coated, or galvanized finish
- Class HA per ASTM A970
- IAPMO UES Listed ER-245 (#4-#14)

FEATURES

- Quick and easy installation
- No bar end preparation
- Installation at the job site
- Gross bearing area of 10x of bar diameter with disk installed towards rebar
- Gross bearing area of 5x diameter of rebar tube with disk installed away from rebar

BENEFITS

- Anchor Disc through-hole permits offset installation in high congestion applications
- Saves time and money
- No fabrication required
- One product for all applications

HOW TO SPECIFY

Specific:

Mechanical connections shall be Bar Lock® Rebar Splices as manufactured by Dayton Superior Corp.

Generic:

The mechanical connection shall meet building code requirements of developing in tension and compression as required by _____ (insert name here). The mechanical connection shall be made from lock shear bolt couplers with serrated gripping rails manufactured from high quality steel. All couplers shall be installed per the manufacturer's approved procedures.

TECHNICAL DATA

APPROVALS / COMPLIANCE

- ACI 318
- State Departments of Transportation
- AASHTO and International Building Code (IBC)
-
-



Size	Outside Dia. (barrel) in.	Outside Dia. (anchor) in.	Length (in.)	Bolt Qty.
#4 - 13MM	1.315	3.000	4.318	3
#5 - 16MM	1.661	3.750	4.838	3
#6 - 19MM	1.902	4.250	5.829	4
#7 - 22MM	1.900	4.250	6.882	5
#8 - 25MM	2.244	5.250	8.205	5
#9 - 29MM	2.898	6.500	7.936	4
#10 - 32MM	2.898	6.500	9.383	5
#11 - 36MM	3.118	7.000	10.768	6
#14 - 43MM	3.500	8.000	12.341	7
#18 - 57MM	4.290	10.000	19.479	12

INSTALLATION

1. Insert the end of the rebar through the coupler until it is flush with or protruding past the end of the anchor disk.
2. Holding the rebar in place, tighten all the bolts until they are hand tight against the rebar.
3. In a random, alternating pattern, tighten all bolts to approximately 50%.
4. In a random, alternating pattern, tighten all bolts to approximately 75%.
5. In a random, alternating pattern, tighten all bolts until all the heads of the bolts shear off.

Note:

- A. Prior to bolt tightening, the serrated rails **MUST** remain aligned in the same position as they were manufactured. If they are damaged or knocked out of alignment while positioning, installation **MUST** cease and a new coupler used.
- B. Bolt tightening **MUST** be done in a random alternating pattern similar to tightening the lug nuts on an automobile wheel.
- C. A high-quality, 1" - pneumatic drive, impact wrench with at least 100 psig air flow and 185 CFM of delivered air through a no less than 0.75" hose **MUST** be used for installation.

RELATED PRODUCTS

- D250SCA Bar Lock® Couplers
- D250L Bar Lock® Couplers

ORDERING INFORMATION

BLACK (MADE IN USA)

Product Code	Description	Weight
145790	#4 - 13MM	2.1 LB
145791	#5 - 16MM	3.8 LB
145792	#6 - 19MM	5.7 LB
145793	#7 - 22MM	6.7 LB
145794	#8 - 25MM	11.6 LB
145795	#9 - 29MM	19.1 LB
145796	#10 - 32MM	22.1 LB
145797	#11 - 36MM	27.9 LB
145798	#14 - 43MM	40.5 LB
145799	#18 - 57MM	86.5 LB

D630 Bar Lock® Compression Only Coupler

The Dayton Superior D630 Compression Coupler is an easy-to-install rebar coupler, perfect for applications requiring a compression-only connection. The D630 couplers are available in sizes #4 [13mm, 10M] through #18 [57mm, 55M] rebar sizes and develop the full ACI Type 2 requirement in compression. For grades 60, 75 and 80 rebar.



To Order:
Specify: (1) quantity, (2) name, (3) bar size.

Example:
1000 D630 Compression Couplers, #18 [57mm, 55M].

FEATURES

- Available in #4 [13mm, 10M] - #18 [57mm, 55M] rebar
- Can be installed on first bar prior to second bar
- Uses readily available ratchets for assembly
- Wide inspection holes at bar end location
- Removable and reusable
- Small profile for tight applications
- Can be used at hoop and stirrup locations
- #4 - #11 tube length - 6"
- #14 & #18 tube length - 8"
- All sizes of D630 compression couplers have four bolts

APPROVALS / COMPLIANCE

- ACI 318, Type 2 (Compression Only)
- ICC AC133, Type 2 (Compression Only)
- State Departments of Transportation (Compression Only)
- AASHTO (Compression Only)
- International Building Codes (IBC), Type 2 (Compression Only)

INSTALLATION

1. Insert first bar into coupler until the end of the bar is visible through the inspection hole
2. Tighten bolts until hand-tight (20 ft-lbs)
3. Insert second bar into coupler until the end of the bar is visible through the inspection hole and in contact with the first bar
4. Tighten bolts until hand-tight (20 ft-lbs)

ORDERING INFORMATION

BLACK (MADE IN USA)

Product Code	Description	Weight
144842	#4 - 13MM	0.58 LB
144843	#5 - 16MM	0.66 LB
144844	#6 - 19MM	0.79 LB
144845	#7 - 22MM	0.87 LB
144846	#8 - 25MM	1.35 LB
144847	#9 - 29MM	1.68 LB
144848	#10 - 32MM	1.93 LB
144849	#11 - 36MM	1.99 LB
144850	#14 - 43MM	3.03 LB
144851	#18 - 57MM	3.86 LB

D260 Bar Lock® Weldable Couplers

Bar Lock Structural Steel Connectors (weldable half couplers) are designed to provide welded connections to structural steel members such as piles, weld plates, beams, columns, etc. Structural Steel Connectors are fabricated with a 45° chamfer to facilitate the welding operation. They are available in rebar sizes #4 through #18 in the S/CA-Series, L-Series, and XL-Series. Structural Steel Connectors are available in black and epoxy coated. Coupler is made from ASTM A519 Grade 10V30 / 10V35 for welding purposes.

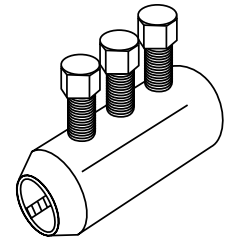

D260 Bar Lock Weldable Coupler

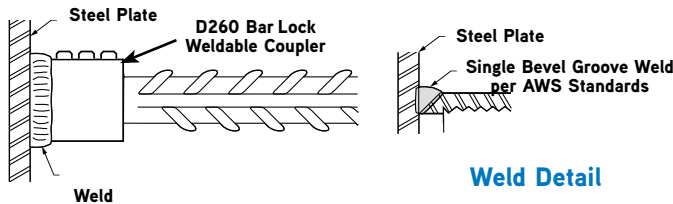

Weld Detail

To Order:
Specify: (1) quantity, (2) name, (3) size.

Example:
300, D250 Bar Lock® Structural Steel Connectors, #7-SCA.

Bar Size Designation			S/CA-Series			S/CA-Series Bolt Specifications			L-Series			L-Series Bolt Specifications		
US	Metric (mm)	CN (M)	Structural Steel Connector Designation	Finished Length with Chamfer (in.)	Coupler Outside Diameter (in.)	Bolt Qty.	Head Size (in.)	Nominal Shear Torque*	Structural Steel Connector Designation	Finished Length with Chamfer (in.)	Coupler Outside Diameter (in.)	Bolt Qty.	Head Size (in.)	Nominal Shear Torque*
#4	[13]	[10]	#4-SCA	2.7	1.3	2	0.5	40	#4-L	3.5	1.3	3	0.5	40
#5	[16]	[15]	#5-SCA	3.0	1.4	2	0.5	80	#5-L	3.9	1.4	3	0.5	80
#6	[19]	[20]	#6-SCA	3.9	1.6	3	0.5	80	#6-L	4.75	1.6	4	0.5	80
#7	[22]	—	#7-SCA	4.75	1.6	4	0.5	80	#7-L	5.65	1.6	5	0.5	80
#8	[25]	[25]	#8-SCA	5.85	2.2	4	0.625	180	#8-L	6.85	2.2	5	0.625	180
#9	[29]	[30]	#9-SCA	5.25	2.6	3	0.75	350	#9-L	6.5	2.6	4	0.75	350
#10	[32]	—	#10-SCA	6.5	2.6	4	0.75	350	#10-L	7.75	2.6	5	0.75	415
#11	[36]	[35]	#11-SCA	7.75	3.1	5	0.75	415	#11-L	9.0	3.1	6	0.75	415
#14	[43]	[45]	#14-SCA	9.0	3.5	6	0.75	475	#14-L	10.3	3.5	7	0.75	475
#18	[57]	[55]	#18-SCA	14.3	4.3	10	0.75	475	#18-L	16.3	4.3	12	0.75	475

Ultimate strength depends on the strength of the field weld and the material to which the coupler is welded.

Bar Size Designation			XL-Series			XL-Series Bolt Specifications		
US	Metric (mm)	CN (M)	Structural Steel Connector Designation	Finished Length with Chamfer (in.)	Coupler Outside Diameter (in.)	Bolt Qty.	Head Size (in.)	Nominal Shear Torque*
#4	[13]	[10]	#4-XL	5.9	1.3	6	0.5	40
#5	[16]	[15]	#5-XL	6.5	1.4	6	0.5	80
#6	[19]	[20]	#6-XL	7.4	1.6	7	0.5	80
#7	[22]	—	#7-XL	8.25	1.6	8	0.5	80
#8	[25]	[25]	#8-XL	10.1	2.2	8	0.625	180
#9	[29]	[30]	#9-XL	10.3	2.6	7	0.75	350
#10	[32]	—	#10-XL	11.6	2.6	8	0.75	415
#11	[36]	[35]	#11-XL	12.8	3.1	9	0.75	415
#14	[43]	[45]	#14-XL	15.3	3.5	11	0.75	475
#18	[57]	[55]	#18-XL	23.2	4.3	17	0.75	475

Ultimate strength depends on the strength of the field weld and the material to which the coupler is welded.

Typical Bar Lock® Coupler Installation

Bar Lock couplers are easy to install and normally do not require any special training or rebar preparation. A typical installation procedure is as follows:

A. Procedure:

1. Insert end of the first bar halfway into the coupler to the center pin. Hold bar in place and hand-tighten all bolts.
2. Insert end of the second bar halfway into the coupler to the center pin. Hold bar in place and hand-tighten all bolts.
3. In a random alternating pattern, tighten all bolts to approximately 50% of the specified bolt torque value.
4. In a random alternating pattern, tighten all bolts to approximately 75% of the specified bolt torque value.
5. Tighten all bolts in a random alternating pattern until all bolt heads shear off.

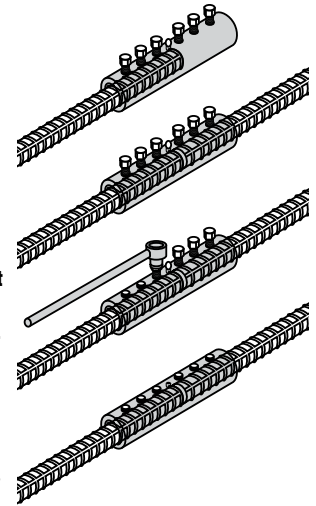

IMPORTANT NOTES:

- a. Prior to bolt tightening the serrated rails **MUST** remain aligned in the same position as they were manufactured. If damaged or knocked out of alignment while positioning, installation **MUST** cease and a new coupler used to replace damaged coupler.
- b. Bolt tightening **MUST** be done in a random alternating pattern similar to tightening the lug nuts on an automobile wheel (i.e., 2-4 then 1-3).

B. Installation Tools:

A high-quality 1"-drive pneumatic impact wrench is required for sizes #8 thru #18. The requirements for air flow is 100 psig of operating pressure and 185 cfm of delivered air to the impact wrench through a ¾" - 1" air hose. Sizes #4 thru #7 may be installed with smaller impact wrenches.

C. Answers to frequently asked questions:

1. **Approvals:** Bar Lock couplers exceed the requirements of the International Building Code and state DOTs and are Listed by IAPMO UES - ER-319.
2. **Center-pin:** Bar Lock couplers are manufactured with a removable center pin for easy reference to the center of the coupler. As each bar is inserted into the coupler it will butt against the center pin providing the confirmation the the rebar is inserted the proper distance within the coupler. The bar ends might not actually butt against one another.
3. **Serrated rails:** The internal grip rails are held into place by a simple "positional weld" only. During bolt tightening it is common this position weld may break loose, but this will not affect performance.
4. **Shear bolts:** The shearing of the bolt-heads simply confirms adequate torque has been achieved.
5. **Bar-ends:** The rebar may be shear cut, flame cut or sawn and generally require no special bar-end preparation for use with Bar Lock couplers. **Transportation:** Assembled coupler samples must be restricted from rotation when transporting to a testing facility. It is recommended that samples be strapped to a skid lined with damping material like packing or egg crate foam.

D. Epoxy-Coated Rebar Applications

Bar Lock Couplers can be used in conjunction with epoxy-coated rebar. When used with epoxy-coated, Grade 60 rebar, Bar Lock L-Series couplers develop 135% Fy strength and Bar Lock S/CA-Series Couplers develop 125% Fy strength. To achieve the standard performance strengths of 100% Fy, the epoxy must be completely removed from the rebar in the region where the coupler engages the rebar.

Laboratory test results

Bar Lock couplers are designed to exceed industry requirements for splicing Grade 60, 75 and 80 rebar of both A615 and A706 designation including the specification requirements of the International Building Code (IBC), ACI, Caltrans, the City of Los Angeles, and all other state departments of transportation. Bar Lock couplers are test-certified to qualify as:

S/CA-Series: ACI/IBC - Type 1 splice; Meet 125% Fy Grade 60

L-Series: ACI/IBC - Type 2 splice; Meet 100% Fu and 125% Fy Grade 60

XL-Series: ACI/IBC - Type 2 splice, Meet 100% Fu of specified strength of rebar, and 125% Fy Grade 60, 75, and 80

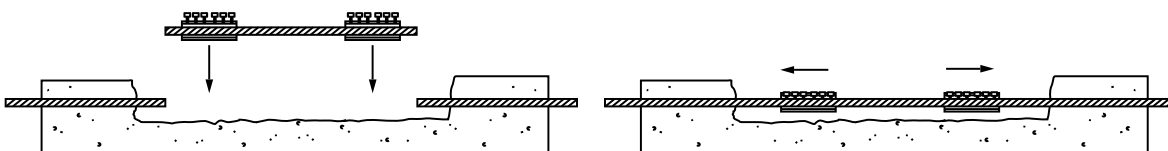

Typical replacement of corroded or damaged rebar in existing concrete.

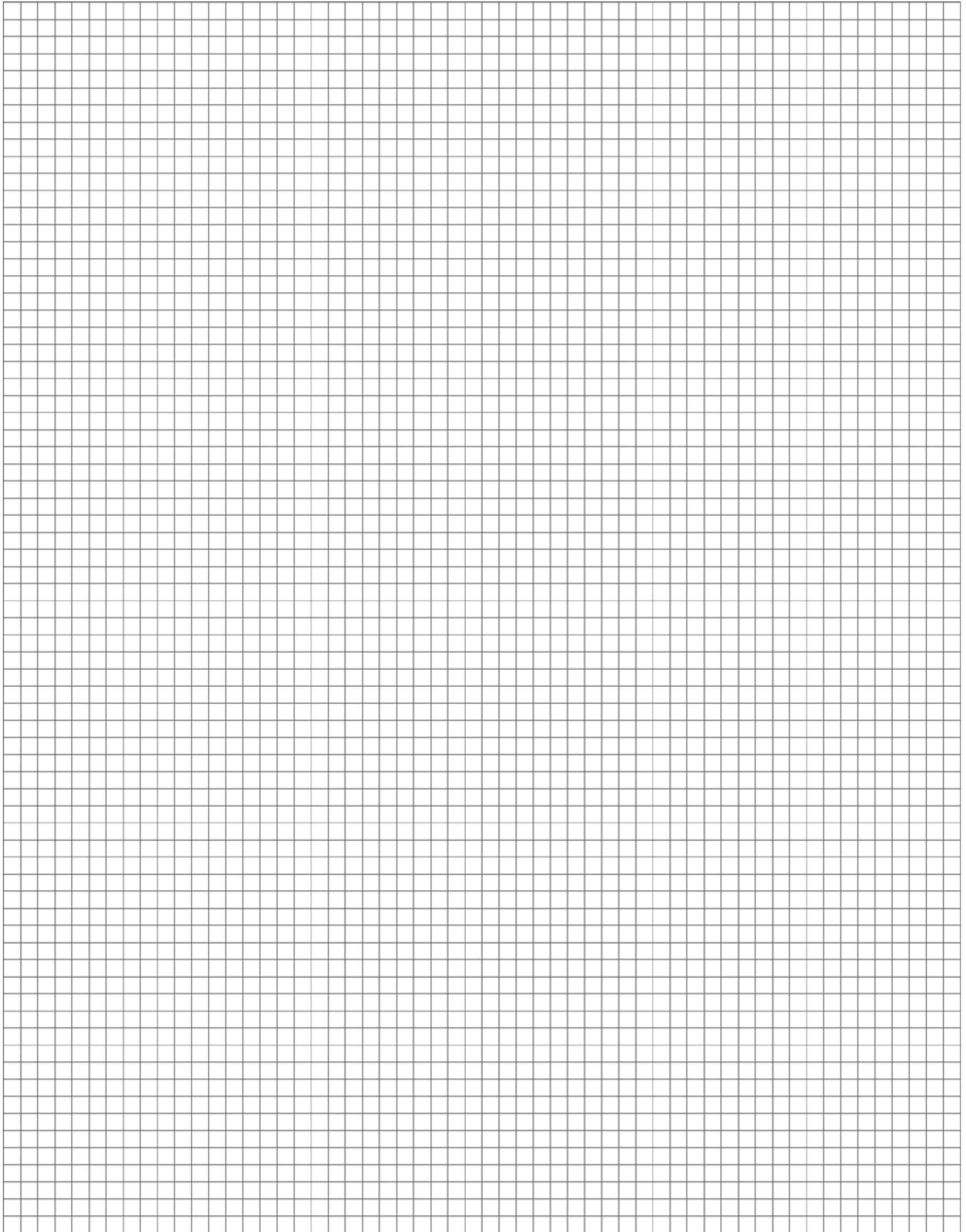

The Taper-Lock® System

Features and Benefits

- IAPMO UES Listed Evaluation Reports ER-0245 and ER-0319
- Portable and robust design allows you to take the system wherever you need it.
- Long lasting chasers for previously unheard of efficiency! Spend less money on new blades, and save your crew from unnecessary downtime.
- Revolutionary high-speed taper cut more than doubles the production of conventional cutters, allowing you to beat deadlines and reduce costs.
- Uses environmentally friendly water based cutting fluids for onsite safety and hazard compliance.
- Strong unit withstands tough projects. Straightforward process makes operation and repair easy.

Splice Rebar On-site, in a Fraction of the Time

You already rely on Taper-Lock® Couplers from Dayton Superior – the company you trust is proud to offer the portable, high-speed taper cut solution! Turn the system that's already been proven on sites throughout North, Central, and South America into your on-site advantage. Dayton Superior is the only company able to bring the reliable Taper-Lock design to fabricators.

Use the Dayton Taper-Lock on Your Next Job Site

The compact design saves room in your fabrication shop or on the job with all the advantages and one-quarter the size of similar machines, it's time to re-think rebar splicing! Strength certification and test results are available upon request through the qualified Dayton Superior Dealer network throughout North America.

TYPICAL SPECIFICATIONS:

Specific:

Mechanical connections shall be Taper-Lock® taper threaded couplers as manufactured by Dayton Superior Corp.

Generic:

The mechanical connection shall meet building code requirements of developing in tension and compression as required by _____ (insert name here). The mechanical connection shall be the positive locking, taper threaded type coupler manufactured from high quality steel. The bar ends must be taper threaded using the manufacturer's bar threading equipment to ensure proper taper and thread engagement. All couplers shall be installed per the manufacturer's approved procedures.



D310 Taper-Lock® Standard Coupler

Product Description:

The D310 Taper-Lock is used to join any bar-to-bar connection of the same size, where one bar can be rotated. This simplifies rebar splicing in areas where rebar congestion prevents the use of long lap splices. Engagement of the bar within the coupler is simplified by the taper thread which aids in alignment.

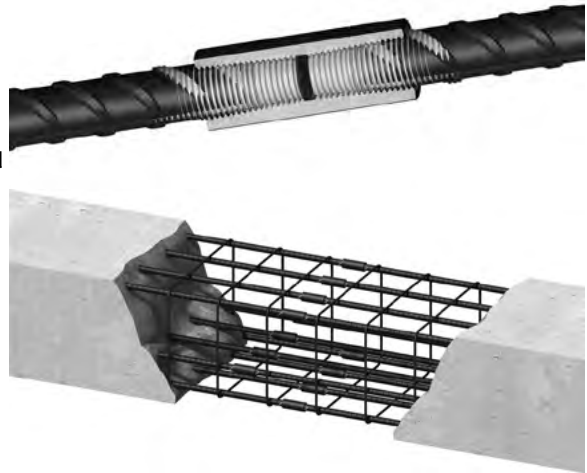

Product Features and Benefits:

- Used in 80% of all connections
- The compact design of the coupler ensures suitability for use in confined situations where space is restricted or where the loss of cover must be minimized
- Reduces engineering design time
- Eliminates rebar congestion
- Provides Type 2 splicing capacities and simplifies load paths
- Complies with ACI, Caltrans, IBC, and Ministries of Transportation for Ontario and Quebec
- Approved for use in fatigue applications
- IAPMO UES Listed - ER-319 Note: for grade 60, 75 and 80

Product Specifications:

- Extension of Taper-Lock product line
- Accommodates rebar sizes #4 through #18
- Available in Black, Epoxy, Galvanized, or Stainless Steel
- Type 2 Splice
- Connect bars of the same size using an internal sleeve with two right hand tapered threads
- For use with Grade 60, 75, 80 or 100 rebar

To Order:

Specify: (1) quantity, (2) name, (3) rebar size, (4) finish, (5) Made in USA requirement.

Example:

500 pcs., D310 Taper-Lock® Standard Coupler, #6, Black, Made in USA not required.

Taper-Lock®

Product Codes

Bar Size			Black (Made in USA)	Epoxy (Made in USA)	Black	For Rebar Up To Grade
US	Metric (mm)	CN (m)				
#4	[13]	[10]	127020	127258	126389	80
#5	[16]	[15]	127021	127259	126390	80
#6	[19]	[20]	127022	127260	126391	80
#7	[22]	—	127023	127261	126392	80
#8	[25]	[25]	127024	127262	126393	80
#9	[29]	[30]	127025	127263	126394	80
#10	[32]	—	127026	127264	126395	80
#11	[36]	[35]	127027	127265	126396	80
#12	[40]	—	145101	145102	145103	80
#14	[43]	[45]	127028	127266	126397	60
#18	[57]	[55]	127019	127267	126398	60
#14B	[43]	[45]	100471	100577	100473	80
#18B	[57]	[55]	100472	100578	100474	80



Nominal Engagement

Bar Size			"A"		"B" (Nominal)		OD
US	Metric (MM)	CN (M)	US	(mm)	US	(mm)	US
#4	[13]	[10]	2.362	[60]	1.024	[26]	0.88"
#5	[16]	[15]	2.756	[70]	1.221	[31]	1.00"
#6	[19]	[20]	2.874	[73]	1.281	[32.5]	1.13"
#7	[22]	—	3.189	[81]	1.399	[35.5]	1.38"
#8	[25]	[25]	3.622	[92]	1.615	[41]	1.44"
#9	[29]	[30]	4.016	[102]	1.812	[46]	1.63"
#10	[32]	—	4.488	[114]	2.049	[52]	1.75"
#11	[36]	[35]	4.921	[125]	2.246	[57.5]	1.88"
#12	[40]	—	5.472	[139]	2.539	[64.5]	2.38"
#14 & #14B	[43]	[45]	5.827	[148]	2.719	[69]	2.38"
#18 & #18B	[57]	[55]	7.638	[194]	3.625	[92]	3.25"

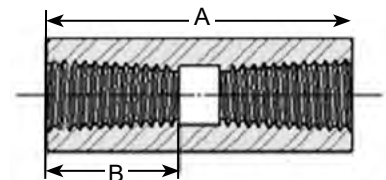

Installation: D310 Taper-Lock Standard Coupler

STEP 1

The coupler is normally supplied fixed to the reinforcing bar, ready to be installed and cast in concrete.



STEP 2

After casting the concrete and when ready to extend, remove the thread protector from the coupler. Position the continuation bar in the sleeve and rotate the bar into the coupler.

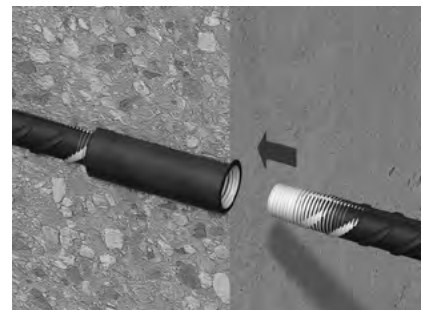

STEP 3

Continue to screw the bar into the coupler until hand tight.



STEP 4

Inspect the connection to verify connection is hand tight. (Dayton Superior defines hand tight as equivalent to 5 ft-lbs of torque.).

D320 Taper-Lock® Transitional Coupler

Product Description:

The D320 Taper-Lock is used to join two reinforcing bars of different sizes. It is commonly used for economic designs and columns where the diameter of the rebar reduces as the columns extend up the structure.



Product Features and Benefits:

- Eliminates rebar congestion
- Reduces engineering design time
- Allows for the connection of two different size bars
- Provides Type 2 splicing capacities and simplifies load paths
- Complies with ACI, Caltrans, IBC and Ministries of Transportation for Ontario and Quebec
- Approved for use in fatigue applications
- IAPMO UES Listed - ER-319

Product Specifications:

- Extension of Taper-Lock product line
- Accommodates all rebar configurations
- Available in Black, Epoxy, or Galvanized
- Type 2 Splice
- Threads in internal sleeve correspond to the appropriate bar size
- For use with Grade 60, 75 or 80 rebar

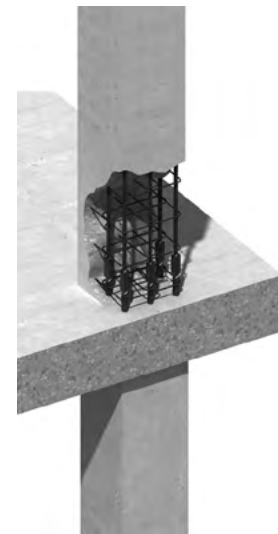

Taper-Lock®

Product Codes

Bar Size		
US	Metric (MM)	CN (M)
#4-#5	[13-16]	[10-15]
#5-#6	[16-19]	[15-20]
#6-#7	[19-22]	—
#7-#8	[22-25]	—
#8-#9	[25-29]	[25-30]
#9-#10	[29-32]	—
#10-#11	[32-36]	—
#11-#14	[36-43]	[35-45]
#14-#18	[43-57]	[45-55]

To Order:
Specify: (1) quantity, (2) name, (3) rebar size, (4) finish.

Example:
500 pcs., D320 Taper-Lock®
Transitional Coupler, #6-#7,
Black.

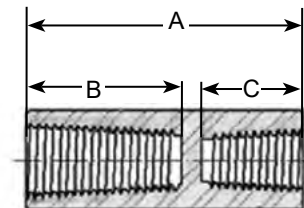

Other sizes available upon request

Nominal Engagement

Bar Size			"A"		"B" (Nominal)		"C" (Nominal)		OD
US	Metric (MM)	CN (M)	US	[mm]	US	[mm]	US	[mm]	US
#4-#5	[13-16]	[10-15]	2.7953	[71]	1.5748	[40]	1.0236	[26]	1.00"
#5-#6	[16-19]	[15-20]	3.0315	[77]	1.6535	[42]	1.378	[35]	1.13"
#6-#7	[19-22]	—	3.2283	[82]	1.7931	[45.5]	1.437	[36.5]	1.38"
#7-#8	[22-25]	—	3.6024	[91.5]	2.0079	[51]	1.5945	[40.5]	1.44"
#8-#9	[25-29]	[25-30]	4.0157	[102]	2.2047	[56]	1.811	[46]	1.63"
#9-#10	[29-32]	—	4.4488	[113]	2.4409	[62]	2.0079	[51]	1.75"
#10-#11	[32-36]	—	4.9213	[125]	2.6772	[68]	2.2441	[57]	1.88"
#11-#14	[36-43]	[35-45]	5.5906	[142]	3.1102	[79]	2.4803	[63]	2.38"
#14-#18	[43-57]	[45-55]	6.9291	[176]	4.0157	[102]	2.9134	[74]	3.25"

Installation: D320 Taper-Lock Transitional Coupler

When installing the D320 Transitional Coupler, the larger of the two bars must be connected first, the smaller bar is to be connected after the coupler is tightened on the larger rebar. This process ensures that the smaller bar does not receive the higher torque used to connect the larger bar. As an alternative, it is permitted to connect the smaller bar to the coupler first. If the smaller bar is connected first, a second wrench can be used to keep the coupler from rotating while the second connection to the larger bar is made.

STEP 1

The coupler is normally supplied fixed to the reinforcing bar, ready to be installed and cast in concrete.



STEP 2

After casting the concrete and when ready to extend, remove the thread protector from the coupler. Position the continuation bar in the sleeve and rotate the bar into the coupler.

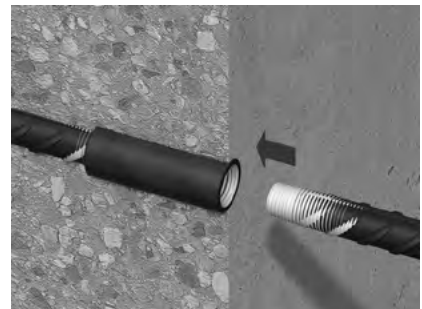

STEP 3

Continue to screw the bar into the coupler until hand tight.

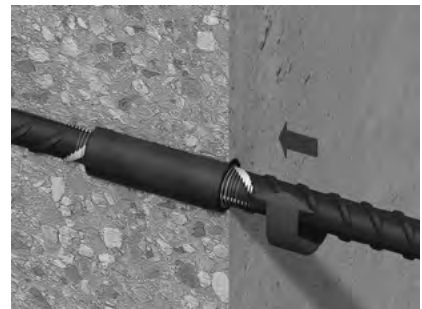

STEP 4

Inspect the connection to verify connection is hand tight. (Dayton Superior defines hand tight as equivalent to 5 ft-lbs of torque.)

D330 Taper-Lock® Positional Coupler

Product Description:

The D330 Taper-Lock is used to join two bars of the same size where neither bar can be rotated. Typical applications are hook bar connections and column to slab connections.



Product Features and Benefits:

- Eliminates rebar congestion
- Reduces engineering design time
- Rebar never has to be rotated
- Provides Type 2 splicing capacities and simplifies load paths
- Complies with ACI, Caltrans, IBC and Ministries of Transportation for Ontario and Quebec
- Approved for use in fatigue applications
- Adjustability of coupler allows it to be a closer between two fixed bars
- IAPMO UES Listed - ER-319

Product Specifications:

- Extension of Taper-Lock product line
- Accommodates rebar sizes #4 through #18
- Available in Black or Black Made in USA
- Type 2 Splice
- Uses a two part system for connecting rebar
- For use with Grade 60, 75 or 80 rebar

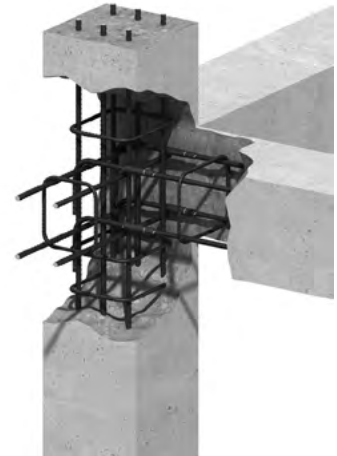

Taper-Lock®

Product Codes

Bar Size			Black (Made in USA)	Black
US	Metric (MM)	CN (M)		
#4	[13]	[10]	127065	128268
#5	[16]	[15]	127066	128269
#6	[19]	[20]	127067	128270
#7	[22]	—	127068	128271
#8	[25]	[25]	127069	128272
#9	[29]	[30]	127070	128273
#10	[32]	—	127071	128274
#11	[36]	[35]	127072	128275
#12	[40]	—	145107	145109
#14	[43]	[45]	127073	128276
#14B	[43]	[45]	100475	100477
#18	[57]	[55]	127074	128277
#18B	[57]	[55]	100476	100478

Other sizes available upon request

To Order:
Specify: (1) quantity, (2) name, (3) rebar size, (4) finish, (5) Made in USA requirement.

Example:
500 pcs., D330 Taper-Lock® Positional Coupler, #6, Black, Made in USA not required.

Nominal Engagement

Bar Size			MAXIMUM BAR TO BAR DISTANCE		MINIMUM BAR TO BAR DISTANCE		SLEEVE OD	STUD OD
US	Metric (MM)	CN (M)	US	[mm]	US	[mm]	US	US
#4	[13]	[10]	4.3"	[109.2]	3.3"	[83.8]	0.98"	0.87"
#5	[16]	[15]	4.8"	[121.0]	3.6"	[91.4]	1.18"	0.98"
#6	[19]	[20]	4.7"	[119.4]	3.6"	[91.4]	1.38"	1.10"
#7	[22]	—	5.8"	[147.3]	4.3"	[109.2]	1.50"	1.26"
#8	[25]	[25]	6.7"	[170.2]	4.8"	[121.0]	1.89"	1.50"
#9	[29]	[30]	6.8"	[172.7]	4.9"	[124.5]	1.89"	1.65"
#10	[32]	—	7.2"	[182.9]	5.4"	[137.2]	2.17"	1.89"
#11	[36]	[35]	8.0"	[203.2]	5.9"	[149.9]	2.36"	2.17"
#12	[40]	—	8.5"	[215.0]	6.2"	[157.5]	2.50"	2.25"
#14	[43]	[45]	9.4"	[238.8]	6.8"	[172.7]	2.76"	2.36"
#14B	[43]	[45]	9.4"	[238.8]	6.8"	[172.7]	2.76"	2.36"
#18	[57]	[55]	12.0"	[304.8]	8.6"	[218.4]	3.54"	3.15"
#18B	[57]	[55]	12.0"	[304.8]	8.6"	[218.4]	3.54"	3.15"

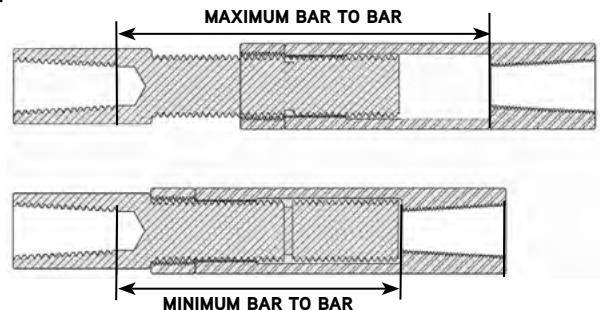

Installation: D330 Taper-Lock Positional Coupler

Step 1

The female section of the positional coupler is normally cast flush in concrete. The installer must take care to protect the internal threads and prevent the ingress of concrete. Once cast and ready to extend, the male end complete with locknut can be screwed into place.



Step 2

Position the continuation bar as near as possible to the coupler fitted to the cast-in-bar.

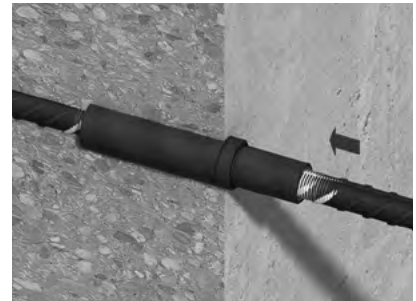

Step 3

Run the male component onto the continuation bar until fully engaged and hand tight.

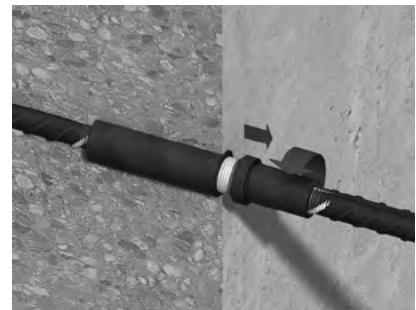

Step 4

Inspect the connection to verify connection is hand tight. (Dayton Superior defines hand tight as equivalent to 5 ft-lbs of torque).

Step 5

Run locking ring up against female component until hand right. (Dayton Superior defines hand tight as equivalent to 5 ft-lbs of torque).

Installation Inspection

No threading beyond the Inspection Groove should be visible on the male component extending from the female component.

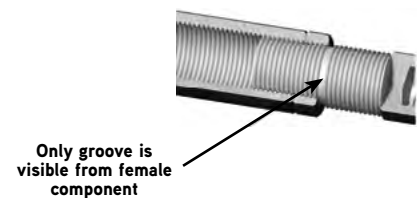

Maximum Extension

D340 Taper-Lock® Flange Coupler

Product Description:

The D340 Taper-Lock simplifies the forming process by **eliminating the need to cut or drill the formwork**. It is used for segmental pours, precast applications, formed applications, and future work applications.

Product FEATURES AND BENEFITS:

- Reduces engineering design time
- Provides a safer working environment by eliminating protruding rebar ends through formwork
- Eliminates the need to cut or drill formwork
- Complies with ACI, Caltrans, IBC, and Ministries of Transportation for Ontario and Quebec, Canada
- Eliminates rebar congestion
- Provides Type 2 splicing capacities and simplifies load paths
- Approved for use in fatigue applications
- IAPMO UES Listed - ER-319 Note: for grade 60, 75 and 80



Product Specifications:

- Extension of Taper-Lock product line
- Accommodates rebar sizes #4 through #18
- Available in Black, Epoxy, or Galvanized
- Type 2 Splice
- Fastened to formwork by nails
- For use with Grade 60, 75, 80 or 100 rebar



Taper-Lock®

Product Codes

Bar Size			Black (Made in USA)	Epoxy (Made in USA)	Black
US	Metric (MM)	CN (M)			
#4	[13]	[10]	127790	127847	127881
#5	[16]	[15]	127791	127848	127882
#6	[19]	[20]	127792	127849	127885
#7	[22]	—	127793	127850	127888
#8	[25]	[25]	127794	127851	127890
#9	[29]	[30]	127795	127852	127892
#10	[32]	—	127796	127853	127894
#11	[36]	[35]	127797	127854	127896
#12	[40]	—	145104	145105	145106
#14	[43]	[45]	127798	127855	128373
#14B	[43]	[45]	100582	100584	100586
#18	[57]	[55]	127799	127856	128374
#18B	[57]	[55]	100583	100585	100587

To Order:
Specify: (1) quantity, (2) name, (3) rebar size, (4) finish, (5) Made in USA requirement.

Example:
500 pcs., D340 Taper-Lock® Flange Coupler, #6, Black, Made in USA not required.

Nominal Engagement

Bar Size			"A"		"B"	
US	Metric (MM)	CN (M)	US	[mm]	US	[mm]
#4	[13]	[10]	2.362	[60]	1.024	[26]
#5	[16]	[15]	2.756	[70]	1.221	[31]
#6	[19]	[20]	2.874	[73]	1.281	[32.5]
#7	[22]	—	3.189	[81]	1.399	[35.5]
#8	[25]	[25]	3.622	[92]	1.615	[41]
#9	[29]	[30]	4.016	[102]	1.812	[46]
#10	[32]	—	4.488	[114]	2.049	[52]
#11	[36]	[35]	4.921	[125]	2.246	[57.5]
#12	[40]	—	5.472	[139]	2.539	[64.5]
#14 & #14B	[43]	[45]	5.827	[148]	2.719	[69]
#18 & #18B	[57]	[55]	7.638	[194]	3.625	[92]

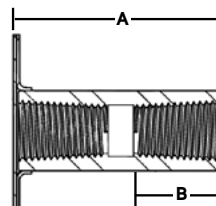

Installation:

1. Ensure that threads are clean, in good condition, and conform to gauge requirements as published in the Taper-Lock Machine Operations Manual before assembly.
2. Assemble D340 onto rebar hand tight (5 foot-pounds).

D350 Taper-Lock® Seismic End Anchor Disc

Product Description:

The D350 Taper-Lock Seismic End Anchor Discs simplify rebar splicing in areas where rebar congestion prevents the use of long lap splices or large diameter hooked rebar. The D350 Taper-Lock Seismic End Anchor Discs can be used for end anchoring, stirrup replacements, continuous splicing, and heavy anchorage of light standards and other signage.

Product Features And Benefits:

- Eliminates rebar congestion and aids in concrete placement
- Eliminates the need for hooked rebar
- Reduces engineering design time
- Improves safety related issues on the job site by reducing protruding dowels
- Complies with ASTM A970, ACI, Caltrans, IBC and Ministries of Transportation for Ontario and Quebec
- Develops full strength with hand-tighten installation
- Class HA per ASTM A970

Product Specifications:

- Extension of Taper-Lock product line
- Accommodates rebar sizes #4 through #18
- Available in Plain or Epoxy
- Gross Bearing Area of 10Ab
- IAPMO UES Listed ER-245 Note: for grade 60, 75 and 80
- For use with Grade 60, 75, 80 or 100 rebar

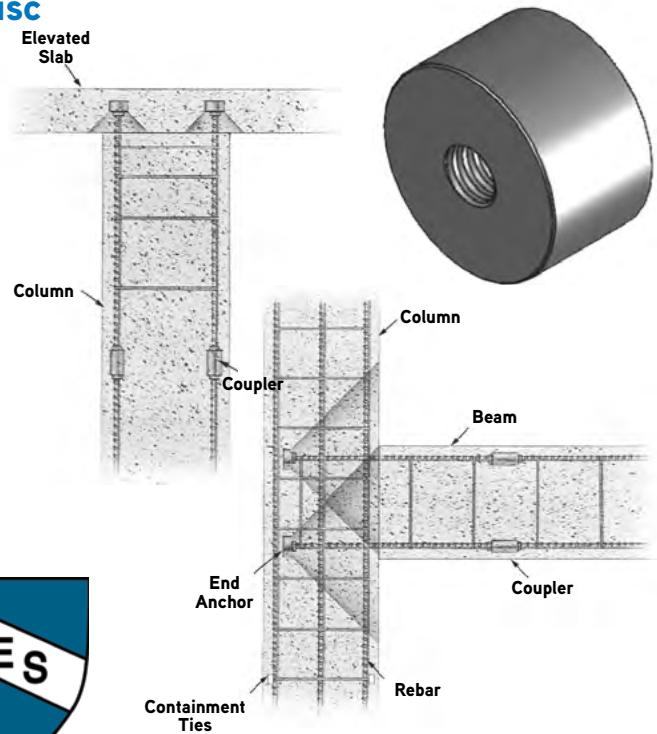

Taper-Lock®

Product Codes - D350 Taper-Lock End Anchor

Bar Size			Black (Made in USA)	Epoxy (Made in USA)	Black
US	Metric (MM)	CN (M)			
#4	[13]	[10]	127940	128017	128221
#5	[16]	[15]	127941	128018	128222
#6	[19]	[20]	127942	128019	128223
#7	[22]	—	127943	128020	128224
#8	[25]	[25]	127944	128021	128225
#9	[29]	[30]	127945	128022	128226
#10	[32]	—	127946	128023	128227
#11	[36]	[35]	127947	128024	128228
#12	[40]	—	100591	100593	100592
#14	[43]	[45]	127948	128025	128229
#14B	[43]	[45]	100595	100597	100596
#18	[57]	[55]	127949	128026	128230
#18B	[57]	[55]	100599	100601	100600

To Order:
Specify: (1) quantity, (2) name, (3) rebar size, (4) finish, (5) Made in USA requirement.

Example:
500 pcs., D350 Taper-Lock® Seismic End Anchor Disc, #6, Black, Made in USA not required.

Installation:

1. Ensure that threads are clean, in good condition, and conform to gauge requirements as published in the Taper-Lock Machine Operations Manual before assembly.
2. Assemble D350 into rebar hand tight (5 foot-pounds).

D351 Taper-Lock® End Anchor Disc

Product Description:

The D351 Taper-Lock End Anchor Discs simplify rebar splicing in areas where rebar congestion prevents the use of long lap splices or large diameter hooked rebar. The D351 Taper-Lock End Anchor Discs can be used for end anchoring, stirrup replacements, continuous splicing, and heavy anchorage of light standards and other signage.

Product Features and Benefits:

- Eliminates rebar congestion and aids in concrete placement
- Eliminates the need for hooked rebar
- Reduces engineering design time
- Improves safety related issues on the job site by reducing protruding dowels
- Complies with ASTM A970, ACI, Caltrans, IBC and Ministries of Transportation for Ontario and Quebec
- Develops full strength with hand-tighten installation
- Class HA per ASTM A970

Product Specifications:

- Extension of Taper-Lock product line
- Accommodates rebar sizes #4 through #18
- Available in Plain, Epoxy, or Galvanized
- Gross Bearing Area of 5Ab
- IAPMO UES Listed ER-245 Note: for grade 60, 75 and 80
- For use with Grade 60, 75, 80 or 100 rebar

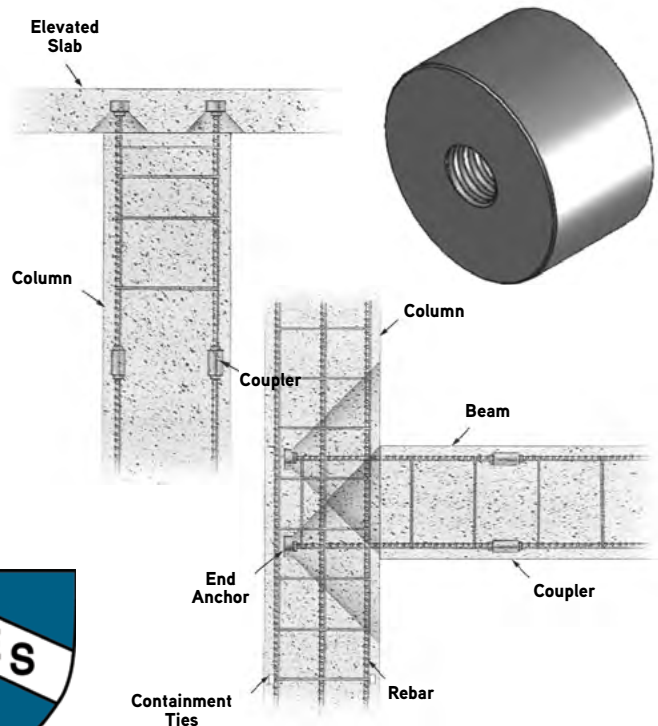

Taper-Lock®

Product Codes - D351 Taper-Lock End Anchor

Bar Size			Black (Made in USA)	Epoxy (Made in USA)
US	Metric (MM)	CN (M)		
#4	[13]	[10]	128430	128420
#5	[16]	[15]	128431	128421
#6	[19]	[20]	128432	128422
#7	[22]	—	128433	128423
#8	[25]	[25]	128434	128424
#9	[29]	[30]	128435	128425
#10	[32]	—	128436	128426
#11	[36]	[35]	128437	128427
#12	[40]	—	145110	145111
#14	[43]	[45]	128438	128428
#14B	[43]	[45]	100606	100607
#18	[57]	[55]	128439	128429
#18B	[57]	[55]	100610	100611

To Order:
 Specify: (1) quantity, (2) name, (3) rebar size, (4) finish, (5) Made in USA requirement.

Example:
 500 pcs., D351 Taper-Lock® End Anchor Disc, #6, Black, Made in USA not required.

Installation:

1. Ensure that threads are clean, in good condition, and conform to gauge requirements as published in the Taper-Lock Machine Operations Manual before assembly.
2. Assemble D351 into rebar hand tight (5 foot-pounds).

D358 Taper-Lock® Female Bolt Head

Product Description:

The D358 Taper-Lock Female Bolt Head is a Type 2 rebar coupler used to connect rebar and provide anchorage. It consists of an integral nailing flange, a coupler forged from the end of the rebar, tapered female threads, and a forged hex bolt end anchor. The D358 is made from USA melted and rolled steel.

Application

The D358 Taper-Lock Female Bolt Head is used to connect rebar between segmental concrete pouring and provide embedment anchorage. It may be attached to formwork through the integral nailing flange.

Product Specification

- Rebar sizes #4 (13mm) through #11 (36mm)
- Available with clipped or full flange
- Available in plain, epoxy coated, or galvanized finish
- Available in carbon, weldable, chromium, or stainless steel

Product Features and Benefits

- Ability to use the flange and nails to attach the system to formwork
- Available in standard and customized lengths
- Taper-Lock Type 2 threads
- Gross bearing area of 5Ab
- Easier to use and up to 25% faster installation
- Versatility to meet project needs



To Order:

Specify: (1) quantity, (2) name, (3) rebar size, (4) length, (5) rebar.

Example:

500 pcs., D358 Taper-Lock® Female Bolt Head, #5 x 30" long, Epoxy Coated ASTM A615 Grade 60.

D360 Taper-Lock® Weldable Coupler

Product Description:

The Taper-Lock D360 Weldable Couplers provide a convenient means of connecting reinforcing bars to structural steel plates or sections. Shorter than the standard coupler, it has a tapered thread at one end. The other end is welded directly to the steel.

The couplers are produced using ASTM A108 CD 8620 steel

The Taper-Lock Weldable Coupler is suitable for welding to structural steels. The load conditions at the connection must be determined by the engineer along with the type and size of weld required. Another important consideration is the type of electrode to be used, which must be matched to the properties of the plate and tube, and to the site conditions under which the welding will be undertaken. Welders should be qualified for the type of weld required.



Product Features and Benefits:

- The compact design of the coupler ensures suitability for use in confined situations where space is restricted or where the loss of cover must be minimized
- Reduces engineering design time
- Eliminates rebar congestion
- Provides Type 2 splicing capacities and simplifies load paths
- Complies with ACI, Caltrans, IBC, and Ministries of Transportation for Ontario and Quebec
- Approved for use in fatigue applications

To Order:

Specify: (1) quantity, (2) name, (3) rebar size.

Example:

500 pcs., D360 Taper-Lock® Weldable Coupler, #6.

Product Specifications:

- Extension of Taper-Lock product line
- Accommodates rebar sizes #4 through #18
- Type 2 Splice
- For use with Grade 60, 75, 80 or 100 rebar

Product Codes D360 Taper-Lock Weldable Coupler

Bar Size			Black (Made in USA)	Thickness (in.)	Outer Diameter (in.)	20° Chamfer (in.)
US	Metric (MM)	CN (M)				
#4	[13]	[10]	128385	1.0	1.3	0.25
#5	[16]	[15]	128386	1.2	1.3	0.25
#6	[19]	[20]	128387	1.3	1.3	0.38
#7	[22]	—	128388	1.4	1.5	0.38
#8	[25]	[25]	128389	1.6	1.6	0.50
#9	[29]	[30]	128390	1.8	1.9	0.56
#10	[32]	—	128391	2.0	2.3	0.63
#11	[36]	[35]	128392	2.3	2.4	0.75
#12	[40]	—	145113	2.6	1.6	0.88
#14	[43]	[45]	128393	2.7	2.8	0.93
#18	[57]	[55]	128394	3.6	3.8	1.13

Installation:

1. Ensure that threads are clean, in good condition, and conform to gauge requirements as published in the Taper-Lock Machine Operations Manual before assembly.
2. Assemble D360 into rebar hand tight (5 foot-pounds).

D368 Taper-Lock® Form Saver

Product Description:

Made in America, taper threaded, mechanical coupler (D368) forged from the structural reinforcement. It includes an integral nailing flange used to attach the coupler to formwork. When used in conjunction with the male threaded Taper-Lock Bar (D370), the formwork does not require rebar holes in order to have a continuous path of reinforcement.



Product Features and Benefits:

- Installation not requiring a torque wrench which means it is easier to use and saves time
- Ability to use the flange and nails to attach the system to formwork eliminates repair costs associated with holes for rebar
- Components can be fabricated to order with straight, bent, hooked, or double ended for versatility to meet project needs
- Taper-Lock tapered threads is designed for hand tightening and faster installation



Product Specifications:

- Available in rebar sizes #4 (13mm) through #11 (36mm)
- Performs in tension and compression as a Type 2 connection
- Available in plain rebar finish or epoxy coated
- May contribute to LEED credits

Taper-Lock®

Bar Size Designation			Type 1	Type 2			Type 3			Type 4		R min	Washer Dia.
US	Metric (mm)	CN (M)	A min	A min *	B min	A min	B min	C min	A min	Tolerance			
#4	[13]	[10]	12"	4"	2.5"	4"	2.5"	2.5"	12"	+0 -3/8"	1.25"	1.875"	
#5	[16]	[15]	14"	5"	2.5"	5"	3.75"	2.5"	12"	+0 -3/8"	1.875"	2"	
#6	[19]	[20]	16"	6"	3"	6"	4.5"	3"	14"	+0 -1/2"	2.25"	2.375"	
#7	[22]	—	16"	7"	3.5"	7"	5.25"	3.5"	16"	+0 -5/8"	2.625"	2.5"	
#8	[25]	[25]	16"	8"	4"	8"	6"	4"	16"	+0 -3/4"	3"	2.5"	
#9	[29]	[30]	16"	9"	4.5"	9"	9.5"	4.5"	16"	+0 -1"	4.75"	2.75"	
#10	[32]	—	16"	10"	5"	10"	10.75"	5"	16"	+0 -1"	5.375"	3"	
#11	[36]	[35]	16"	11"	5.5"	11"	12"	5.5"	16"	+0 -1"	6"	3.125"	

To Order:
Specify: (1) quantity, (2) name (3) type, (4) rebar size, (5) Dimensions.

Example:
500 pcs., D368 Taper-Lock® Form Saver, Type 1, Single ended, #11, 36".

* Tolerance on bending is +0" -1"

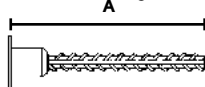

Type 1
Single End

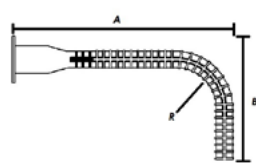

Type 2
90° Bend

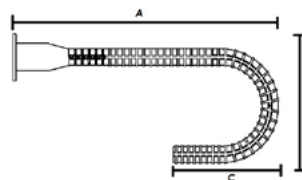

Type 3
180° Hook



Type 4
Double End

Installation:

1. Ensure that threads are clean, in good condition, and conform to gauge requirements as published in the Taper-Lock Machine Operations Manual before assembly.
2. Assemble D368 into rebar hand tight (5 foot-pounds).

D370 Taper-Lock® Threaded Bar

Product description:

Made in America, taper threaded reinforcing bar (D370) is available in single ended, bent, hook ended, double ended or a fully custom configuration. It requires no torque wrench to assemble and can be used with any Taper-Lock splicing product.

Product Features and Benefits:

- Installation does not require a torque wrench is easier to use and saves time
- Ability to use the flange and nails to attach the system to forms eliminates repair costs associated with holes for rebar
- Components can be fabricated to order with straight, bent, hooked, or double ended for versatility to meet project needs
- Taper-Lock tapered threads is designed for hand tightening and faster installation

Product Specifications:

- Available in rebar sizes #4 (13mm) through #11 (36mm)
- Provides Type 2 splicing capacities and simplifies load paths
- Available in plain rebar finish or epoxy coated
- May contribute to LEED credits

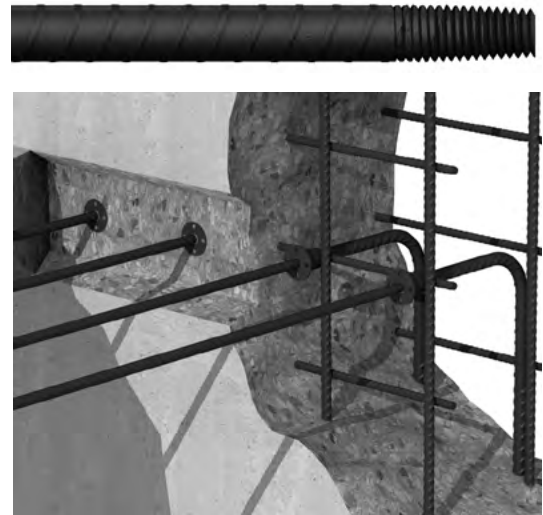

Taper-Lock®

Bar Size Designation			Type 1	Type 2			Type 3			Type 4	Type 5	Type 6	R min
US	Metric (mm)	CN (M)	A min	A min*	B min	A min	B min	C min	A min	A min	A min		
#4	[13]	[10]	9"	4"	2.5"	4"	2.5"	2.5"	12"	12"	12"	1.25"	
#5	[16]	[15]	9"	5"	2.5"	5"	3.75"	2.5"	12"	12"	12"	1.875"	
#6	[19]	[20]	9.25"	6"	3"	6"	4.5"	3"	14"	14"	14"	2.25"	
#7	[22]	-	9.25"	7"	3.5"	7"	5.25"	3.5"	16"	16"	16"	2.625"	
#8	[25]	[25]	15.5"	8"	4"	8"	6"	4"	16"	16"	16"	3"	
#9	[29]	[30]	15.5"	9"	4.5"	9"	9.5"	4.5"	16"	16"	16"	4.75"	
#10	[32]	-	15.75"	10"	5"	10"	10.75"	5"	16"	16"	16"	5.375"	
#11	[36]	[35]	16"	11"	5.5"	11"	12"	5.5"	16"	16"	16"	6"	

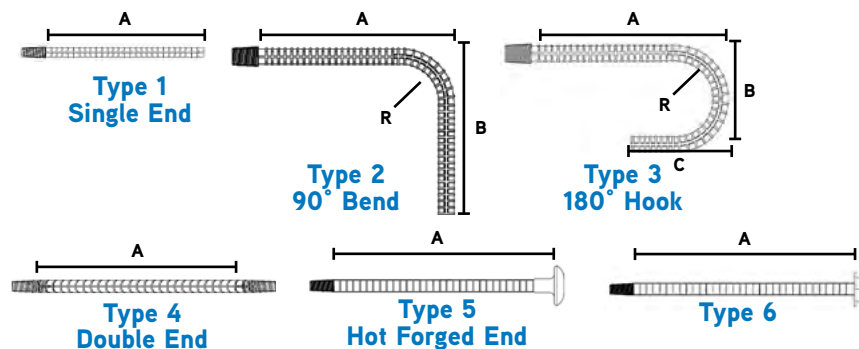

To Order:
Specify: (1) quantity, (2) name (3) type, (4) rebar size, (5) Dimensions.

Example:
600 pcs., D370 Taper-Lock® Threaded Bar, Type 1, Single ended, #11, 36".

* Tolerance on bending is +0" -1"

D382 TAPER-LOCK® THREADED PLUG

The Taper-Lock Threaded Plug fits Dayton Superior Taper-Lock Couplers sizes #4 through #18. The plastic plugs are threaded to provide a positive, secure fit with the coupler. The threaded plugs protect the internal threads of the coupler from external factors such as concrete and water. The plugs have a notch in the top surface for easy removal.

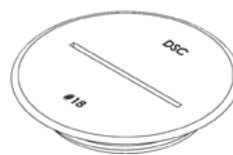

Coupler Size	Product Code	Weight
#4	139963	0.005
#5	139964	0.006
#6	139965	0.006
#7	139966	0.008
#8	139967	0.011
#9	139968	0.017
#10	139969	0.019
#11	139970	0.022
#14	139971	0.024
#18	139972	0.039

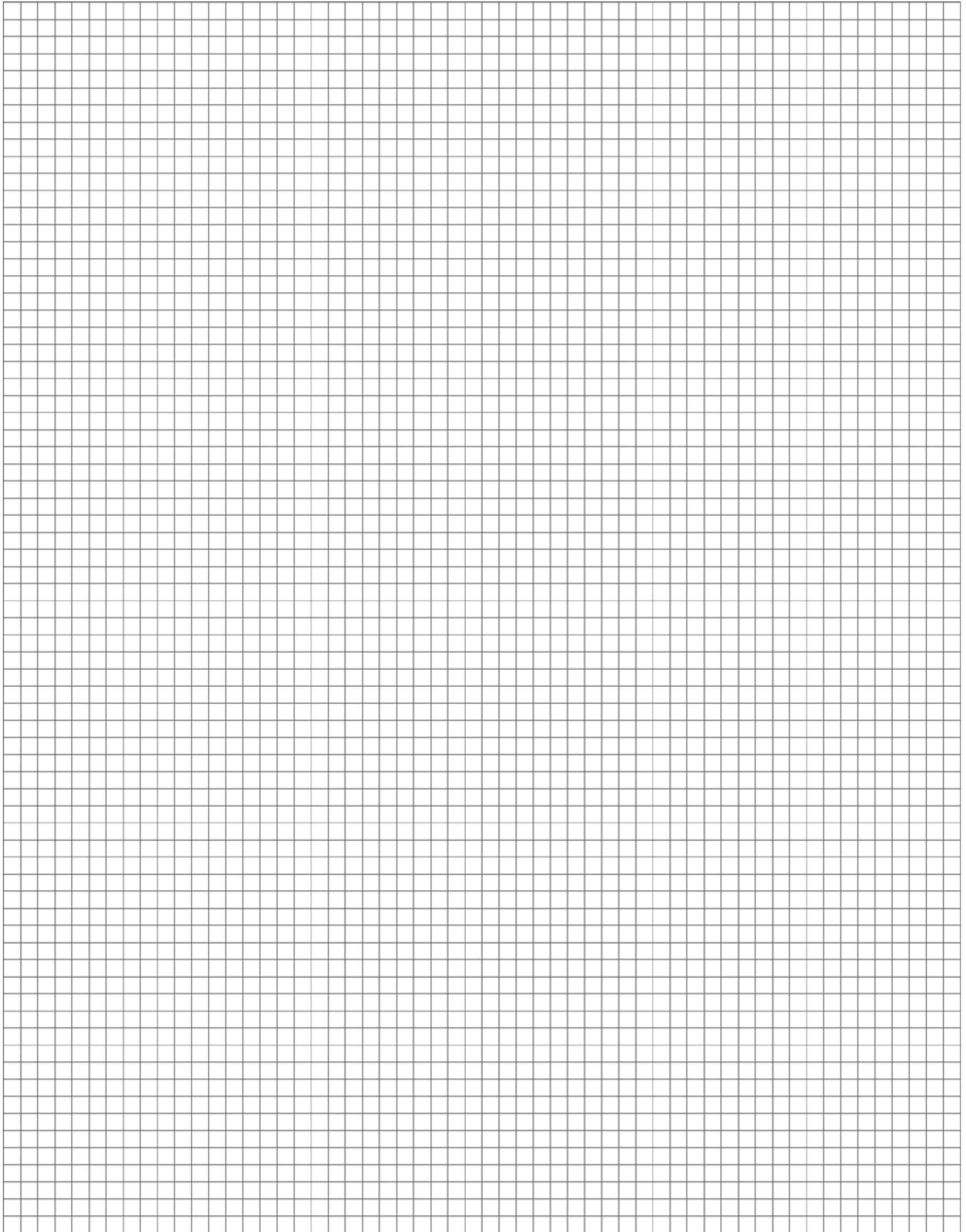

D410 Sleeve-Lock® Grout Sleeve

The Dayton Superior D410 Sleeve-Lock Grout Sleeve is a one-piece mechanical coupler designed to butt-splice reinforcing steel in concrete structures. The Grout Sleeve is available in seven (7) sizes to accommodate deformed bar sizes #4 through #18. Bars of like size or of different sizes can be effectively spliced by the System. Typical sleeve applications include precast and cast-in-place concrete structures.

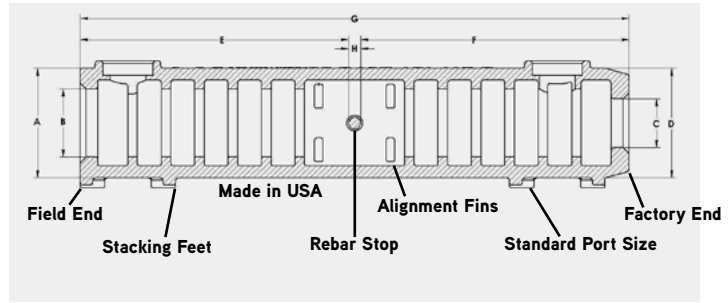

The D410 Sleeve-Lock Grout Sleeve is a ductile casting with a minimum yield strength of 55,000 psi and a minimum tensile strength of 80,000 psi. It exceeds all known building codes and agency standards. The System achieves Type 2 grade 60 strength criteria with the Dayton Superior Sleeve-Lock Grout D490, a high strength, non-shrink grout. Meets the requirements of AASHTO LRFD Bridge Design specification, ACI 318-14 as a type 2 grade 60 connection capable of more than 1,000,000 cycles at 18 ksi cyclic load range.

The Sleeve has several unique features:

- **Rebar Stop** – An integrated post that acts as a precise stop when inserting rebar
- **Alignment Fins** – Positioning fins that keep inserted rebar centered
- **Standard Port Sizes** – Ports designed to accept standard 0.75" SCH40 PVC; ports use the same size PVC
- **Stacking Feet** – Feet used to stabilize the product during shipping and on the shelf while assisting in wire-tying and acting as a platform for a rebar chair.
- **Made In USA** – The sleeve is 100% made in the USA.

SIZE	SLEEVE-LOCK DIMENSIONS (IN.)						REBAR EMBEDMENT LENGTH (IN.)				
	A	B	C	D	G	H	E, MAX	E, MIN	F, MAX	F, MIN	
#4	13MM	2.14	1.26	0.87	2.14	9.50	0.25	4.63	3.30	4.63	3.30
#5	16MM	2.14	1.26	0.87	2.14	9.50	0.25	4.63	4.13	4.63	4.13
#6	19MM	2.61	1.73	1.14	2.61	13.00	0.25	6.38	4.92	6.38	4.92
#7	22MM	2.61	1.73	1.14	2.61	13.00	0.25	6.38	5.71	6.38	5.71
#8	25MM	2.89	2.01	1.42	2.89	16.52	0.38	8.07	6.50	8.07	6.50
#9	29MM	2.89	2.01	1.42	2.89	16.52	0.38	8.07	7.40	8.07	7.40
#10	32MM	3.04	2.16	1.57	3.04	17.99	0.50	8.75	8.19	8.75	8.19
#11	36MM	3.32	2.32	1.73	3.32	19.54	0.50	9.52	8.98	9.52	8.98
#14	43MM	3.73	2.60	2.01	3.73	24.50	0.50	12.00	11.42	12.00	11.42
#18	57MM	4.77	3.27	2.68	4.77	36.00	0.50	17.75	17.00	17.75	17.00

All dimensions are in inches

How to Specify:

Specific: Mechanical splices shall be the Sleeve-Lock® Grout Sleeve System manufactured by Dayton Superior Corporation.

Generic: The mechanical connection shall meet building code requirements of developing in tension and compression, as required, by local standards and codes. Grouting must be performed in accordance with the manufacturer's recommended grouting procedures.

PLAIN

Product Code	Description	Weight
129451	#4 - 13MM TO #5 - 16MM	5 lbs.
129452	#6 - 19MM TO #7 - 22MM	8.31 lbs.
129453	#8 - 25MM TO #9 - 29MM	12 lbs.
129454	#10 - 32MM	13.33 lbs.
129455	#11 - 36MM	19 lbs.
129456	#14 - 43MM	31 lbs.
129457	#18 - 57MM	81 lbs.

EPOXY

Product Code	Description	Weight
143399	#4 - 13MM TO #5 - 16MM	5 lbs.
143400	#6 - 19MM TO #7 - 22MM	8.31 lbs.
143401	#8 - 25MM TO #9 - 29MM	12 lbs.
143402	#10 - 32MM	13.33 lbs.
143403	#11 - 36MM	19.01 lbs.
143404	#14 - 43MM	31.07 lbs.
143405	#18 - 57MM	81.07 lbs.

D490 Sleeve-Lock® Grout

Sleeve-Lock Grout is specifically designed and manufactured by DSC for the Sleeve-Lock System. It is a flowable grout capable of achieving 12,000psi when mixed following the recommended mixing instructions of DSC. Available in 50lb bags, yield per bag, noting that grout used in PVC tubing is accounted for at a nominal 12" length, is as shown in table.

Use only potable water for mixing. A 50 pound (22.7 kg) bag of grout will require approximately 6-7 pints (3-3.51 liters) of water to achieve a flowable consistency. Determine correct water amount by mixing of a test batch prior to commencing grouting operation.

SIZE		SLEEVES PER BAG OF GROUT
#4	13MM	26
#5	16MM	27
#6	19MM	15
#7	22MM	16
#8	25MM	11
#9	29MM	12
#10	32MM	10
#11	36MM	8
#14	43MM	6
#18	57MM	3

Amounts are approximate.

Turbo Grout® LT 12

Turbo Grout LT 12 is approved for use with the Sleeve Lock Grout Sleeve. Turbo Grout LT 12 is designed for use in low temperature applications. Turbo Grout LT 12 can be installed in temperatures as low as 35°F (1.7C).

D487 Sleeve-Lock® Seal Plug

The Sleeve-Lock Seal Plug is a rubberized plug used to seal the connection between the Sleeve-Lock Grout Sleeve and the reinforcing bar. It is designed to keep concrete from entering the inner cavity of the Sleeve-Lock Grout Sleeve on the Factory End and to contain the pumped in grout on the Field End. Per size, the Sleeve-Lock Seal Plug can be used on either end meaning that only one size Sleeve-Lock Seal Plug (qty 2) per sleeve need be stocked.

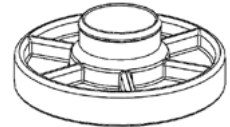

D491 Sleeve-Lock® Form Plug

The Sleeve-Lock Form Plug is a device using a rubberized grommet and a clamping device and used to attach the Sleeve-Lock Grout Sleeve to a piece of formwork i.e. steel, lumber, composite. It is designed to fasten the sleeve to the formwork while keeping concrete out of the sleeve's inner chamber. It is to be used on the Field End only and is not designed to be used as a structural connection.



D492 Sleeve-Lock® ¾" SCH40 PVC

The Sleeve-Lock ¾" SCH40 PVC is standard, off the shelf PVC, used to fill the inner chamber of the Sleeve-Lock Grout Sleeve. Either port of the sleeve uses the same size PVC. It is available locally or through DSC.



D493 Sleeve-Lock® Port Plug

The Sleeve-Lock Port Plug is a plastic plug used during jobsite shipping to plug the ports in order to keep debris from entering the inner chamber of the sleeve. They can also be used to plug the PVC before or after grouting. One size will fit either end port or PVC.



End Anchorage System

The Dayton Superior End Anchorage System is designed to simplify rebar splicing in areas where rebar congestion prevents use of long lap splices or large diameter hooked rebar. The system is designed around a single forge-headed unit in rebar sizes #4 through #11 and is available in various configurations to satisfy numerous applications.

The Dayton Superior End Anchorage System provides a full ductile behavior mode developing ultimate strength capacity of the bars and can be effectively used for end anchoring, stirrup replacements, continuous splicing and heavy anchorage of light standards and other signage.

End Anchorage Advantages:

- Eliminates rebar congestion and aids in concrete placement
- Eliminates the need for hooked rebar
- Reduces engineering design time
- Provides ultimate capacities and simplifies load paths
- Improves safety related issues on the job site by reducing protruding dowels
- Class HA End Anchor conforming to ASTM A970
- IAPMO UES Listed ER-245
- Gross Bearing Area of $5A_b$ or $10A_b$

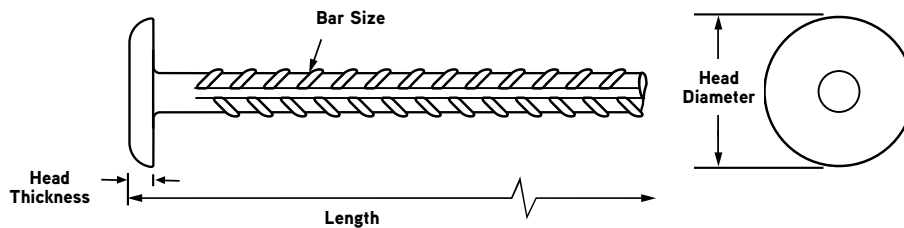

End Anchor

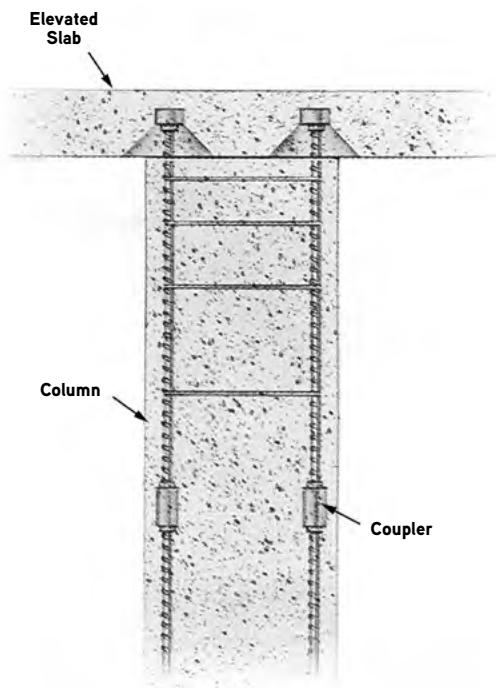

Elevation

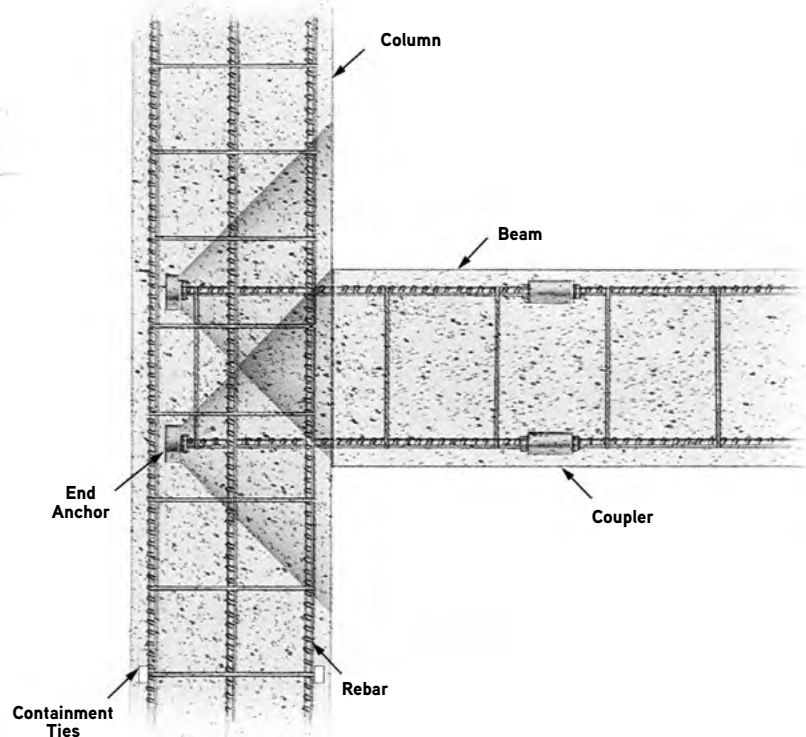

Elevation

End Anchorage

D158B Plain End Anchor (10Ab Head) and D158F Plain End Anchor (5Ab Head)

The Dayton Superior D158B and D158F Plain End Anchor are one-piece, forged-head anchors available in bar sizes #4 through #11. The D158B and D158F anchor have a plain end and can be furnished in lengths up to 60 feet.

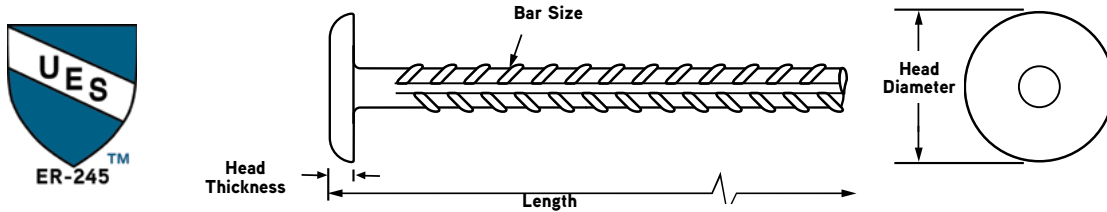

D158B/D158F Plain End Anchor (Forged Head)

Bar Size Designation			Bar Diameter	D158B (Min 9Ab Net Bearing Area)		D158F (Min 4Ab Net Bearing Area)		P _u	Overall Length Min.
US	Metric (mm)	CN (M)		Head Diameter	Head Thickness	Head Diameter	Head Thickness		
#4	[13]	[10]	0.500"	1.596"	.438"	1.128	0.438"	18,000	12"
#5	[16]	[15]	0.625"	1.987"	.500"	1.405	0.500"	27,900	12"
#6	[19]	[20]	0.750"	2.367"	.563"	1.674	0.563"	39,600	12"
#7	[22]	-	0.875"	2.764"	.625"	1.954	0.625"	54,000	12"
#8	[25]	[25]	1.000"	3.172"	.625"	2.243	0.625"	71,100	12"
#9	[29]	[30]	1.128"	3.569"	.688"	2.523	0.688"	90,000	12"
#10	[32]	-	1.270"	4.022"	.750"	2.843	0.750"	114,000	13"
#11	[36]	[35]	1.410"	4.457"	.813"	3.151	0.813"	140,400	14"

D158C Female End Anchor (10Ab Head) and D158G Female End Anchor (5Ab Head)

The Dayton Superior D158C and D158G Female End Anchors are similar to the plain anchor except that the end is forged into a female end complete with UNC or UN threads and washer face. This version of the end anchor system is used effectively for continuous splicing, heavy anchorage for signs/light standards, etc. The D158C and D158G anchors are available in bar sizes #4 through #11.

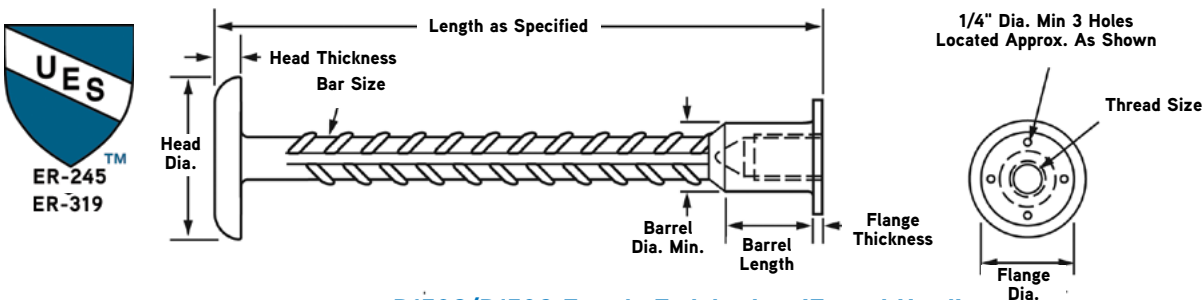

D158C/D158G Female End Anchor (Forged Head)

Bar Size Designation			Bar Diameter	D158C (Min 9Ab Net Bearing Area)		D158G (Min 4Ab Net Bearing Area)		Thread Size	Thread Length	Overall Length Min.	P _u
US	Metric (mm)	CN (M)		Head Diameter	Head Thickness	Head Diameter	Head Thickness				
#4	[13]	[10]	0.500"	1.596"	.438"	1.128"	0.438"	5/8" - 11 UNC	.875"	10.0"	18,000
#5	[16]	[15]	0.625"	1.987"	.500"	1.405"	0.500"	3/4" - 10 UNC	1.000"	12.5"	27,900
#6	[19]	[20]	0.750"	2.367"	.563"	1.674"	0.563"	7/8" - 9 UNC	1.125"	15.0"	39,600
#7	[22]	-	0.875"	2.764"	.625"	1.954"	0.625"	1" - 8 UNC	1.250"	17.5"	54,000
#8	[25]	[25]	1.000"	3.172"	.625"	2.243"	0.625"	1-1/8" - 8 UN	1.375"	20.0"	71,100
#9	[29]	[30]	1.128"	3.569"	.688"	2.523"	0.688"	1-1/4" - 8 UN	1.500"	22.5"	90,000
#10	[32]	-	1.270"	4.022"	.750"	2.843"	0.750"	1-7/16" - 8 UN	1.688"	25.0"	114,000
#11	[36]	[35]	1.410"	4.457"	.813"	3.151"	0.813"	1-9/16" - 8 UN	1.813"	27.5"	140,400

End Anchorage

D158D Male End Anchor (10Ab Head) and D158H Male End Anchor (5Ab Head)

The Dayton Superior D158D and D158H Male End Anchors are similar to the D158C anchor except that the end is furnished with upsized UNC or UN male threads. The D158D and D158H anchors are available in bar sizes #4 through #11.

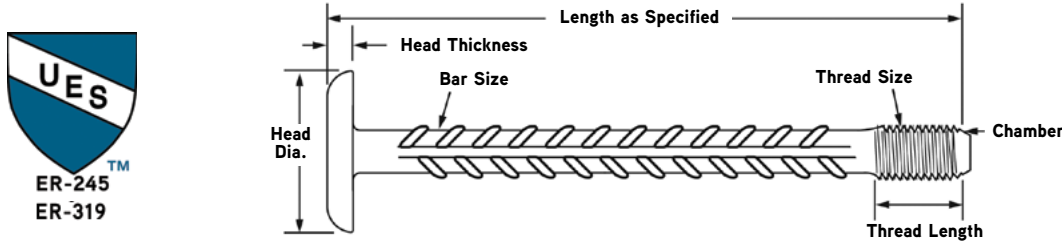

D158D/D158H Male End Anchor (Forged Head)

Bar Size Designation			Bar Diameter	D158D (Min 9Ab Net Bearing Area)		D158H (Min 4Ab Net Bearing Area)		Thread Size	Thread Length	Overall Length Min.	P _u
US	Metric (mm)	CN (M)		Head Diameter	Head Thickness	Head Diameter	Head Thickness				
#4	[13]	[10]	0.500"	1.596"	.438"	1.128	0.438"	5/8" - 11 UNC	.875"	10.0"	18,000
#5	[16]	[15]	0.625"	1.987"	.500"	1.405	0.500"	3/4" - 10 UNC	1.000"	12.5"	27,900
#6	[19]	[20]	0.750"	2.367"	.563"	1.674	0.563"	7/8" - 9 UNC	1.125"	15.0"	39,600
#7	[22]	-	0.875"	2.764"	.625"	1.954	0.625"	1" - 8 UNC	1.250"	17.5"	54,000
#8	[25]	[25]	1.000"	3.172"	.625"	2.243	0.625"	1-1/8" - 8 UN	1.375"	20.0"	71,100
#9	[29]	[30]	1.128"	3.569"	.688"	2.523	0.688"	1-1/4" - 8 UN	1.500"	22.5"	90,000
#10	[32]	-	1.270"	4.022"	.750"	2.843	0.750"	1-7/16" - 8 UN	1.688"	25.0"	114,000
#11	[36]	[35]	1.410"	4.457"	.813"	3.151	0.813"	1-9/16" - 8 UN	1.813"	27.5"	140,400

D158E Double End Anchor (10Ab Head) and D158J Double End Anchor (5Ab Head)

The Dayton Superior D158E and D158J Double End Anchors are fabricated with forged heads on both ends of the anchor. The D158E and D158J anchors can be used effectively in bulkhead areas of heavy rebar congestion. The D158E and D158J anchors are available in bar sizes #4 through #11.

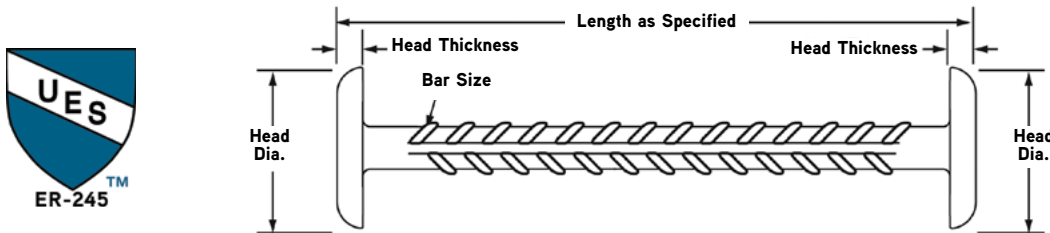

D158E/D158J Double End Anchor (Forged Heads)

Bar Size Designation			Bar Diameter	D158E (Min 9Ab Net Bearing Area)		D158J (Min 4Ab Net Bearing Area)		Overall Length Min.	P _u
US	Metric (mm)	CN (M)		Head Diameter	Head Thickness	Head Diameter	Head Thickness		
#4	[13]	[10]	0.500"	1.596"	.438"	1.128	0.438"	10.0"	18,000
#5	[16]	[15]	0.625"	1.987"	.500"	1.405	0.500"	12.5"	27,900
#6	[19]	[20]	0.750"	2.367"	.563"	1.674	0.563"	15.0"	39,600
#7	[22]	-	0.875"	2.764"	.625"	1.954	0.625"	17.5"	54,000
#8	[25]	[25]	1.000"	3.172"	.625"	2.243	0.625"	20.0"	71,100
#9	[29]	[30]	1.128"	3.569"	.688"	2.523	0.688"	22.5"	90,000
#10	[32]	-	1.270"	4.022"	.750"	2.843	0.750"	25.0"	114,000
#11	[36]	[35]	1.410"	4.457"	.813"	3.151	0.813"	27.5"	140,400

End Anchorage

D158 Two-Piece End Anchor

The Dayton Superior D158 Two-Piece End Anchor consists of a Dowel-In, or splice bar, and a round, square or rectangular anchor plate. The two-piece unit is available in bar sizes #4 through #11 and in various configurations, such as plain, female end, male end and double-ended. The two-piece unit is used effectively for many end anchorage applications where installation restrictions or congestion require the two piece version. The D158 anchor is available in plain or epoxy coated finish. Supplied with standard 10A₆ head area, alternate anchor plate diameters available. Contact Dayton Superior Technical Assistance for additional information.

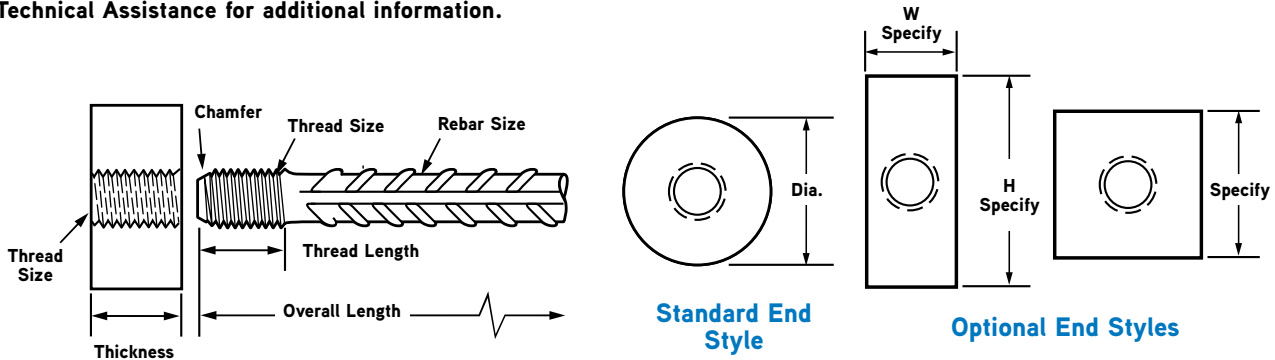

D158 Two-Piece End Anchor

Standard End Style
Optional End Styles
Compatible With All Dayton Superior Splicing Systems

Bar Size Designation			Thread Size	Thread Length	Bar Area (sq. in.)	Minimum Plate Area (sq. in.)	Minimum Plate Thickness	Available End Sizes (Dia.)	P _u
US	Metric (mm)	CN (M)							
#4	[13]	[10]	5/8" – 11 UNC	.875"	.200	2.000	.438"	1.8"	18,000
#5	[16]	[15]	3/4" – 10 UNC	1.000"	.310	3.100	.500"	2.0"	27,900
#6	[19]	[20]	7/8" – 9 UNC	1.125"	.440	4.440	.563"	2.4"	39,600
#7	[22]	–	1" – 8 UNC	1.250"	.600	6.000	.625"	2.9"	54,000
#8	[25]	[25]	1-1/8" – 8 UN	1.375"	.790	7.900	.625"	3.3"	71,100
#9	[29]	[30]	1-1/4" – 8 UN	1.500"	1.000	10.000	.688"	3.6"	90,000
#10	[32]	–	1-7/16" – 8 UN	1.688"	1.270	12.700	.750"	4.1"	114,000
#11	[36]	[35]	1-9/16" – 8 UN	1.813"	1.560	15.600	.813"	4.5"	140,400

To Order:

Specify: (1) quantity, (2) name, (3) end style, (4) bar size, (5) overall length.

Example:

500, D158 Two-Piece End Anchors, female end, #8 bar x 24" overall length.

D108 Headed Dowel-In

The Dayton Superior D108 Headed Dowel-In is a length of deformed rebar with one end enlarged by forging and then threaded, and the other end forged into a bolt head configuration. The D108 Headed Dowel-In is designed for use in congested areas where hooked Dowel-Ins cannot be utilized. Standard length of D108 is 12 times the bar diameter. Other lengths available on request.

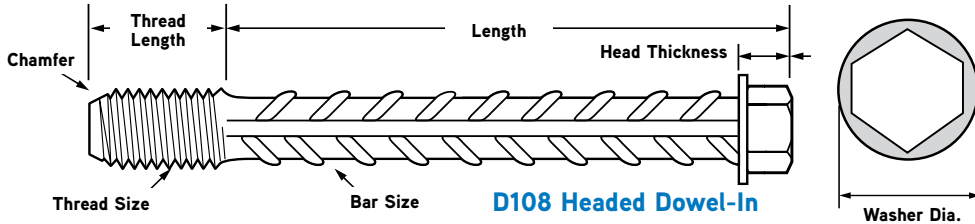

To Order:
Specify: (1) quantity, (2) name, (3) bar size, (4) length.

Example:
500, D108 Headed Dowel-Ins, #6 rebar x 12" long.

Bar Size Designation			Thread Size	Thread Length	Width Across Flats	Washer Diameter	Head Thickness	Min. Length Hex Head Dowel-In
US	Metric (mm)	CN (M)						
#4	[13]	[10]	5/8" - 11 UNC	.875"	1.13	1.13	0.44	6" *
#5	[16]	[15]	3/4" - 10 UNC	1.000"	1.13	1.4	0.44	6" *
#6	[19]	[20]	7/8" - 9 UNC	1.125"	1.13	1.67	0.44	6" *
#7	[22]	-	1" - 8 UNC	1.250"	1.31	1.95	0.56	6" *
#8	[25]	[25]	1-1/8" - 8 UN	1.375"	1.31	2.24	0.75	10" *
#9	[29]	[30]	1-1/4" - 8 UN	1.500"	1.75	2.52	0.75	10" *
#10	[32]	-	1-7/16" - 8 UN	1.688"	1.75	2.84	0.75	12" *
#11	[36]	[35]	1-9/16" - 8 UN	1.813"	2.06	3.15	0.88	12" *

* Plus Thread

D108A Headed Dowel Bar

The Dayton Superior D108A Headed Dowel Bar is designed to help ease hooked rebar congestion. It has excellent anchorage capacities and can be used for common structural anchoring, such as one-sided forming, light standard support, signs, posts, etc. D108A is available in sizes #4 through #11. Standard lengths for D108A is 12 times the bar diameter. Other lengths available on request.

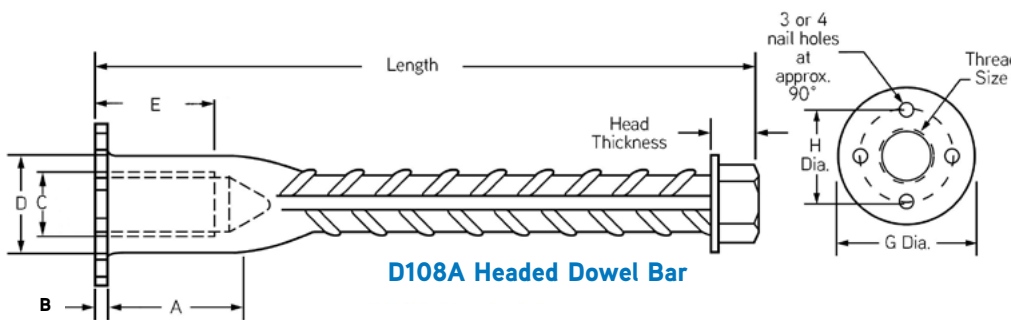

To Order:
Specify: (1) quantity, (2) name, (3) bar size, (4) length.

Example:
500, D108A Headed Dowel Bar, #5 rebar x 9" long.

Bar Size Designation			Thread Size	A	B	C	D	E	Width Across Flats
US	Metric (mm)	CN (M)							
#4	[13]	[10]	5/8" - 11 UNC	1-1/4"	1/8"	11/16"	55/64"	1"	1-1/8"
#5	[16]	[15]	3/4" - 10 UNC	1-9/16"	1/8"	13/16"	1-3/64"	1-1/8"	1-1/8"
#6	[19]	[20]	7/8" - 9 UNC	1-5/8"	1/8"	15/16"	1-15/64"	1-1/4"	1-1/8"
#7	[22]	-	1" - 8 UNC	1-13/16"	1/8"	1-1/16"	1-27/64"	1-3/8"	1-5/16"
#8	[25]	[25]	1-1/8" - 8 UN	2-1/16"	1/8"	1-3/16"	1-19/32"	1-1/2"	1-5/16"
#9	[29]	[30]	1-1/4" - 8 UN	2-3/16"	1/8"	1-5/16"	1-25/32"	1-5/8"	1-3/4"
#10	[32]	-	1-7/16" - 8 UN	2-7/16"	1/8"	1-1/2"	2"	1-13/16"	1-3/4"
#11	[36]	[35]	1-9/16" - 8 UN	2-9/16"	1/8"	1-5/8"	2-7/32"	1-15/16"	2-1/16"

D58 Headed DBR Male Bar

Deformed rebar with one end threaded, and the Dayton Superior D58 Headed DBR Male Bar is a length of deformed rebar with one end enlarged by forging and then threaded, and the other end forged into a bolt head configuration. The D58 Headed DBR Male Bar is designed for use in congested areas where hooked dowel-ins cannot be utilized. Standard length of D58 is 12 times the bar diameter. Other lengths available on request.

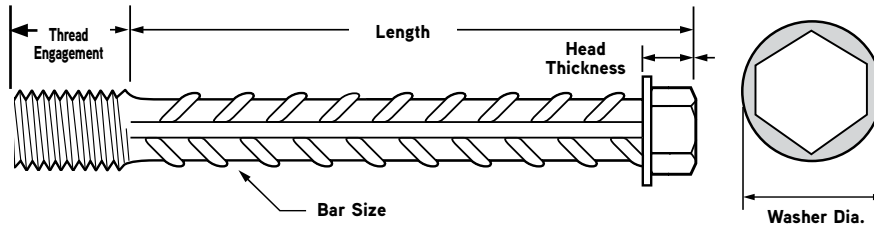

D58 Headed DBR Male Bar

To Order:
Specify: (1) quantity, (2) name, (3) bar size, (4) length.

Example:
500, D58 Headed DBR Male Bar, #6 rebar x 12" long.

Bar Size Designation			D58 Minimum Length Hex Head Dowel In	Thread Data	Thread Engagement	Width Across Flats	Washer Diameter	Head Thickness
US	Metric (mm)	CN (M)						
#4	[13]	[10]	6" *	1/2" - 13 UNC	3/4"	1.13	1.13	0.44
#5	[16]	[15]	6" *	5/8" - 11 UNC	7/8"	1.13	1.4	0.44
#6	[19]	[20]	6" *	3/4" - 10 UNC	1-1/16"	1.13	1.67	0.44
#7	[22]	—	6" *	7/8" - 9 UNC	1-1/4"	1.31	1.95	0.56
#8	[25]	[25]	10" *	1" - 8 UNC	1-7/16"	1.31	2.24	0.75
#9	[29]	[30]	10" *	1-1/8" - 8 UN	1-11/16"	1.75	2.52	0.75
#10	[32]	—	12" *	1-1/4" - 8 UN	1-15/16"	1.75	2.84	0.75
#11	[36]	[35]	12" *	1-3/8" - 8 UN	2-1/16"	2.06	3.15	0.88

* Plus Thread

D58A Headed Dowel Bar

The Dayton Superior D58A Headed Dowel Bar is designed to help ease hooked rebar congestion. It has excellent anchorage capacities and can be used for common structural anchorage, such as one-sided forming, light standard support, signs, posts, etc. The D58A Dowel Bars are available in sizes #4 through #11. Standard lengths for D58A is 12 times the bar diameter. Other lengths available on request.

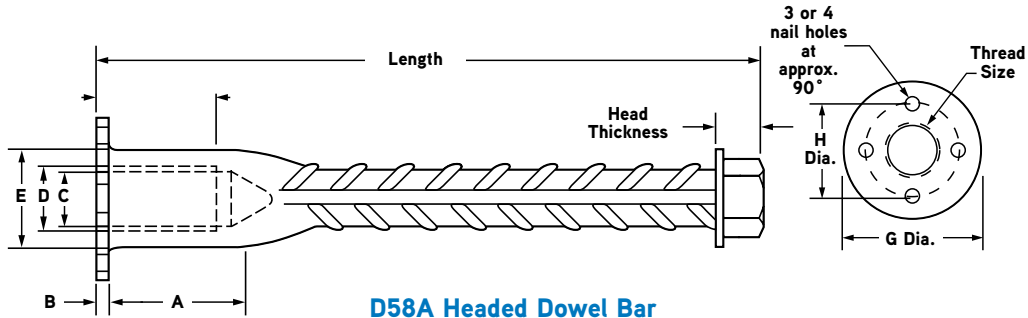

To Order:
Specify: (1) quantity, (2) name, (3) bar size, (4) length.

Example:
500, D58A Headed Dowel Bar, #5 rebar x 9" long.

Bar Size Designation			D58A Minimum Length DB-SAE	Thread Size	A	B	C	D	E	F	G	H	Width Across Flats	Washer Diameter	Head Thickness
US	Metric (mm)	CN (M)													
#4	[13]	[10]	6" O.A.	1/2-13 UNC	1.125	0.125	0.425	0.731	0.855	.875	1.688	1.188	1.13	1.13	0.44
#5	[16]	[15]	6" O.A.	5/8-11 UNC	1.25	0.125	0.522	0.688	1.042	1.000	1.875	1.375	1.13	1.4	0.44
#6	[19]	[20]	6" O.A.	3/4-10 UNC	1.563	0.125	0.657	0.813	1.23	1.125	2.063	0.563	1.13	1.67	0.44
#7	[22]	—	7" O.A.	7/8-9 UNC	1.625	0.125	0.771	0.938	1.417	1.250	2.250	1.75	1.31	1.95	0.56
#8	[25]	[25]	7" O.A.	1-8 UNC	1.813	0.125	0.882	1.063	1.603	1.375	2.438	1.938	1.31	2.24	0.56
#9	[29]	[30]	8" O.A.	1 1/8-8 UN	2.063	0.125	1.007	1.188	1.786	1.500	2.625	2.125	1.75	2.52	0.75
#10	[32]	—	12" O.A.	1 1/4-8 UN	2.188	0.125	1.132	1.313	1.982	1.688	2.813	2.313	1.75	2.84	0.75
#11	[36]	[35]	12" O.A.	1 3/8-8 UN	2.438	0.125	1.32	1.5	2.219	1.813	3.000	2.5	2.06	3.15	0.88

Bar Size Designation			Reinforcing Bar Area (sq. in.)	Minimum Yield (lbs)	Minimum Ultimate (lbs)	Thread Data	Thread Tensile Stress Area (in ²)	125% fy Min. Requirements (lbs)	Minimum Ultimate Tensile Stress (psi)
US	Metric (mm)	CN (M)							
#4	[13]	[10]	0.20	12,000	18,000	1/2-13 UNC	0.1419	15,000	105,708
#5	[16]	[15]	0.31	18,600	27,900	5/8-11 UNC	0.226	26,250	102,876
#6	[19]	[20]	0.44	26,400	39,600	3/4-10 UNC	0.334	33,000	98,802
#7	[22]	—	0.60	36,000	54,000	7/8-9 UNC	0.462	45,000	97,403
#8	[25]	[25]	0.79	47,400	71,100	1-8 UNC	0.606	59,250	97,772
#9	[29]	[30]	1.00	60,000	90,000	1 1/8-8 UN	0.79	75,000	94,937
#10	[32]	—	1.27	76,200	114,300	1 1/4-8 UN	1	95,250	95,250
#11	[36]	[35]	1.56	93,600	140,400	1 3/8-8 UN	1.233	117,000	94,891

End Anchorage

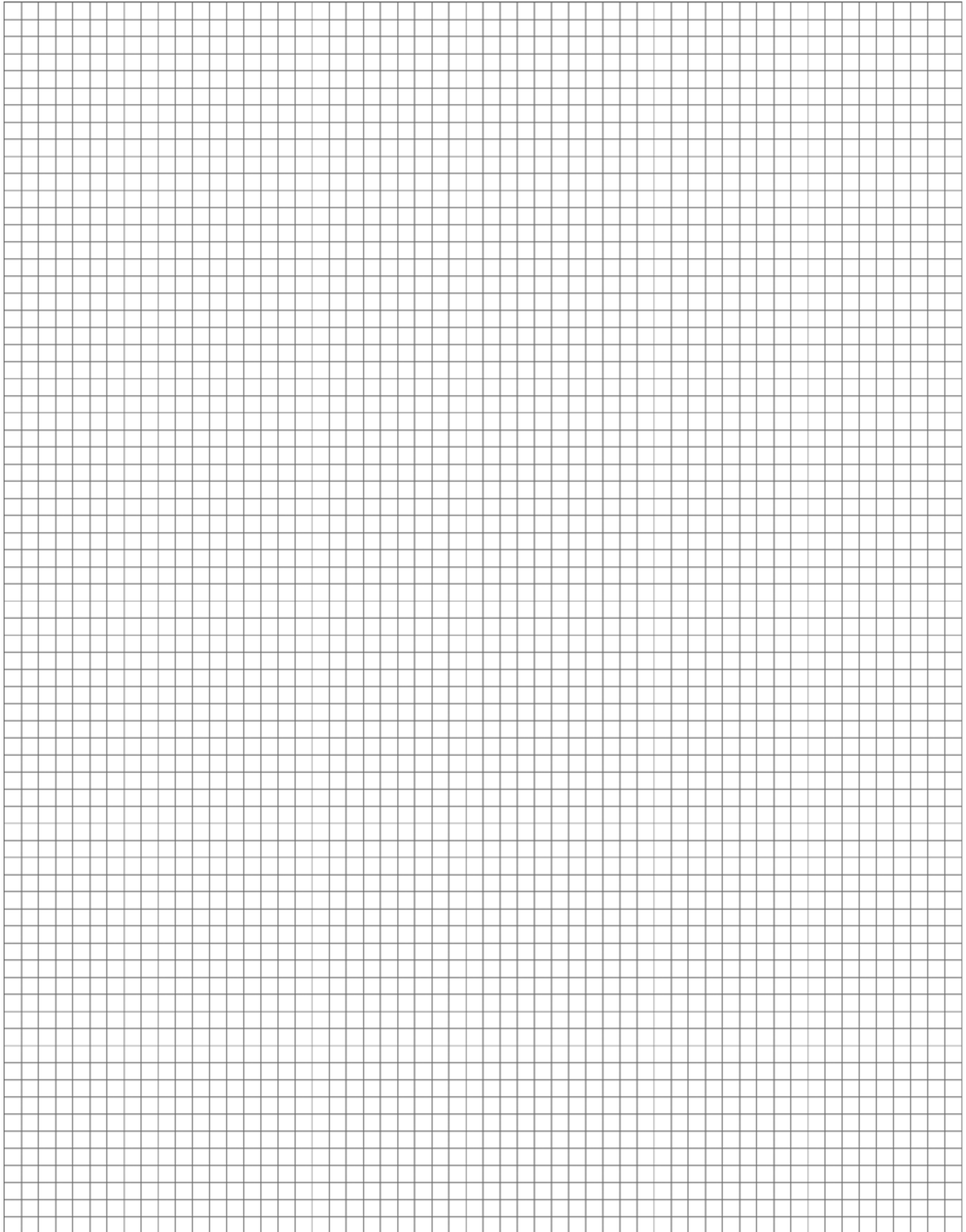

D42 Bag Ties

The Dayton Superior D42 Bag Ties are 16 gauge annealed loop-ended wire ties used for tying rebar and many other non-construction items such as bags and carpet rolls. Bag ties are stocked in 4", 5", 6", 7", 8", 10" and 12" lengths. Other lengths and gauges are available on special order. 4" through 8" bag ties are packaged in coils of 1,000 pieces, five coils per bag. 10" and 12" bag ties are packaged 2,500 pieces per bag.

To Order:
Specify: (1) quantity (sold by bag and/or skid only), (2) name, (3) length.

Example:
5 bags, D42 Bag Ties, 6" long.

D42 Bag Ties

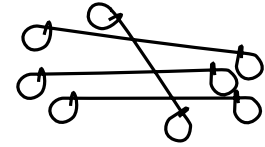

PC110 Rebar Safety Caps

The patented PC110 meets OSHA requirements. It contains a curved steel plate which provides extra protection in falls that occur from an angle, preventing hazardous impalement.

- Protects workers from protruding rebar
- Impalement protection
- One size fits #3 through #11 rebar
- Approved for use with round stakes 5/8" - 7/8" dia.
- Approved for use with flat stakes 1-1/2" x 3/8"
- Safety orange color
- Fully tested and approved (OSHA #C-1730-AG, C-1716-AG)
- Meets Cal OSHA max. drop test requirements
- Complies with Cal OSHA, Section 1712

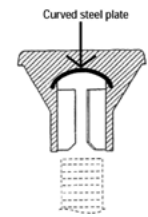
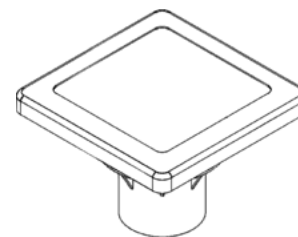

PC110 Rebar Safety Cap

Size	Part	Product Code	Weight	Packaging
#3 [10MM] - #11 [36MM]	PC110	146207	0.56 lb.	100/box

D46 Tie Wire

The Dayton Superior D46 Tie Wire is 16 gauge, black annealed wire used to tie reinforcing steel. This soft, pliable wire is available in 3.5 pound coils with 385 feet of wire in each coil. Packaged twenty coils per carton and 48 cartons per skid.

To Order:
Specify: (1) quantity (sold by carton and/or skid only), (2) name.

Example:
5 cartons, D46 Tie Wire.

D46 Tie Wire



D48 Sure-Guard® Rebar Protective Cap

The Dayton Superior D48 Sure-Guard Rebar Protective Caps have been developed to protect workmen from the hazards of protruding rebar. The D48 cap is available in all rebar sizes, and packaged in bags of 50.

D48 Sure-Guard Rebar Protector



To Order:
Specify: (1) quantity, (2) name, (3) bar size.

Example:
600, D48 Sure-Guard Rebar Protective Caps for #6 rebar.

D55 MetalStrip™

The Dayton Superior D55 MetalStrip™ is a two-piece, prepackaged dowel bar keyway strip available in standard 48" lengths and 2-1/2", 3-1/2", 6" and 8" standard widths. The D55 keyway is designed to stay in place. The ends are typically enclosed with duct tape or rigid insulation plugs. The D55 keyway comes prepackaged with #4 or #5 ASTM A706 grade 60 bendable rebar shaped to job specifications.

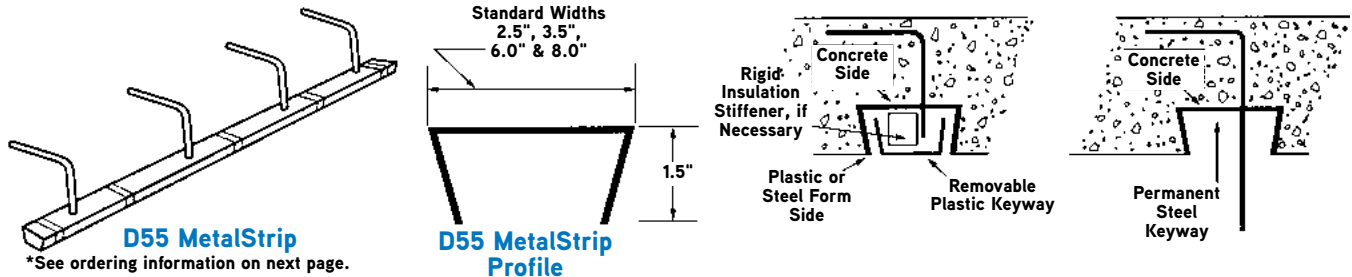

Proper Straightening Procedures

IMPORTANT: The probability of rebar breaks and cracks during straightening increases with cold bar temperatures and impact. User can significantly decrease the potential incidence of bar breaks or cracks when straightening if:

- A) The bar is free of frost and its temperature is above freezing.
- B) The bars are straightened with a proper inside diameter pipe in a 2-step process as described below.

STEP 1. Pry out 90° prebent rebar enough to allow steel pipe to slide over it. In some cases a crowbar may be necessary. Push pipe as tight as possible against factory bend. **DO NOT ATTEMPT TO RE-STRAIGHTEN REBAR WITHOUT PIPE!**

STEP 2. Once the pipe is as tight as possible against the factory bend, the rebar can be straightened using the pipe. Continue straightening until the position of #4 bars reach approximately 45° and the position of #5 bars reach approximately 30°. Then slide the pipe tight against the factory bend again and continue to bend #4 bars through another 45° and #5 bars through another 30°. The #4 bars will then be straightened, while the process described above needs to be repeated through another 30° for #5 bars. If properly executed, these procedures should result in offsets or kinks in the bend region between one-half and three-quarters of a bar diameter.

IMPORTANT: Proper field-restraightening procedures require that workmen have a firm footing from which to apply straightening pressure. A firm base is, of course, also important to reduce risk of injury if the bar would suddenly break during straightening.

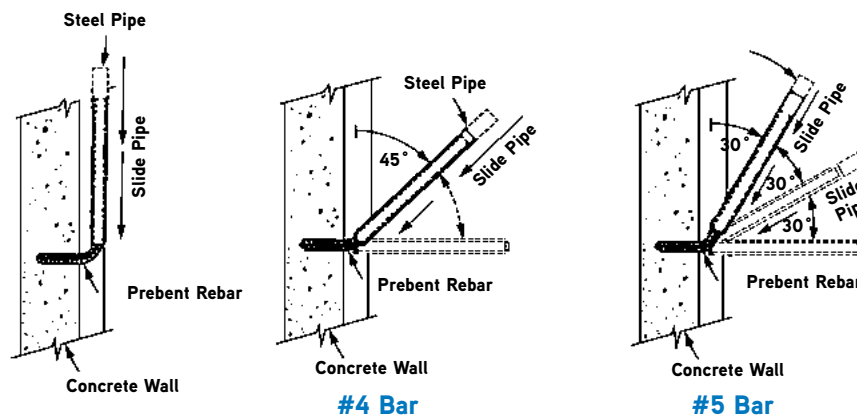

How to Order D55 MetalStrip

Legend	A	B	C	D	E1	E	F	G	H	I	J	K	L	M	N	O
Example	48	D55	2	4	5.75	8.25	1.50	2.00	I	G	B	A	A	10	16	8

A) Quantity

Number of pieces

B) Product Name

D55 MetalStrip™. All metal strips can be provided. Please note under Special Features.

C) Number of Rows

"1"=1 Row

"2"=2 Rows

"S"=Special

D) Rebar Size

"4"=#4 Grade 60 US Rebar

"5"=#5 Grade 60 US Rebar

"S"=Special

E1) End Spacing (Quarter inch increments)

E) Rebar Spacing, Typical (Quarter inch increments)

No limitations on rebar spacing

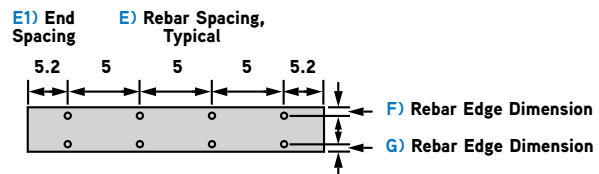

F) and G) Rebar (Quarter inch increments)

Each dimension is between the bar hole centerline and keyway edge. (The standard dimension is 1".) Use letter "C" to indicate hole should be centered in keyway width.

H) Anchor Shape

"J" = AC1 180° STD Hook Geometry

"L" = AC1 90° STD Hook Geometry

"I" = Straight Bar

"S" = Special Anchor Configuration

[As specified by engineer and noted as Special Feature(SF)]

I) Anchor Direction

J) Keyway Strip Width

"A" = 2.5"

"B" = 3.5"

"C" = 6"

"D" = 8"

"S" = Special

K) Keyway Strip Depth

"A" = 1.5"

"S" = Special

L) Keyway Strip Length

"A" = 48"

"B" = 60"

"S" = Special

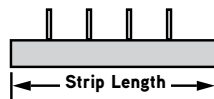

M) Total Anchor Depth (Inch increments)

Includes keyway depth

N) Lap Splice Length (Inch increments)

O) Dowel Bar Tail Length (Inch increments)

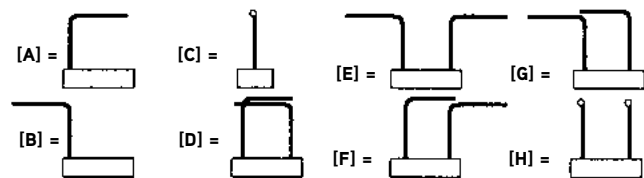

Anchor Direction Legend

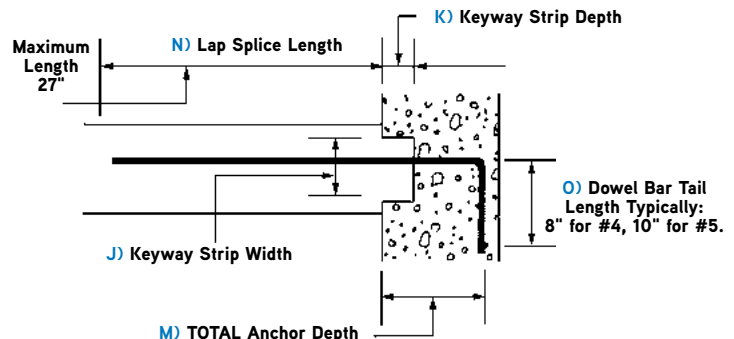

P154 DB Attachment Magnet

The P154 Attachment Magnet can be used to attach a DB or D50 coupler to a metal form. Simply thread the attachment into the coupler, and the magnet will attach to the metal form. Once the concrete has cured, pull the form work from the magnets. The re-usable Attachment Magnets can be removed from the threaded couplers.

Product Code	DB Bar Size	D50 Bar Size	Face Diameter	Magnet Thickness	Thread Length	Thread Size
126857	#4	#5	2-1/4"	1"	3/4"	5/8" - 11 UNC
128161	#5	#6	2-1/2"	1"	7/8"	3/4" - 10 UNC
128162	#6	#7	2-3/4"	1"	1"	7/8" - 9 UNC
127769	#7	#8	3"	1"	1-1/8"	1" - 8 UNC
128163	#8	#9	3"	1"	1-1/4"	1-1/8" - 8 UN
128164	#9	#10	3-1/4"	1"	1-3/8"	1-1/4" - 8 UN
128165	#10	---	3-1/2"	1"	1-1/2"	1-7/16" - 8 UN
128166	#11	---	3-3/4"	1"	1-5/8"	1-9/16" - 8 UN



F72 Threaded Steel Setting Plug

The Dayton Superior F72 Threaded Steel Setting Plug eliminates the need for large holes in the form to secure splicing products. The F72 plug is basically a socket set screw that has been drilled through and tapped with a #8-32 thread. This enables the plug to be nailed to a wood form or bolted to a metal form. The plugs can be easily removed from the splicer with a standard hex wrench and reused as needed. F72 plugs are available in 3/8", 1/2", 5/8", 7/8" and 1" diameters.

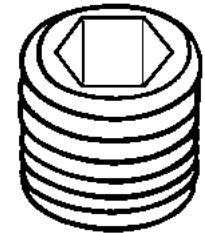

F72 Threaded Steel Setting Plug

To Order:
Specify: (1) quantity, (2) name, (3) diameter.

Example:
100, F72 Threaded Steel Setting Plugs, 1/2" diameter.

F74 Threaded Plastic Setting Plug

The Dayton Superior F74 Threaded Plastic Setting Plug is similar to the F72 plug with the exception of its plastic construction. The plug can be used to seal female splicing threads and to set the splicer in the form. F74 plugs are available in 3/8" through 1" diameters.

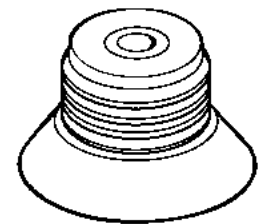

F74 Threaded Plastic Setting Plug

To Order:
Specify: (1) quantity, (2) name, (3) diameter.

Example:
400, F74 Threaded Plastic Setting Plugs, 5/8" diameter.

Supports for Rebar and Wire Mesh

Dayton Superior manufactures a complete line of rebar and/or mesh supports.

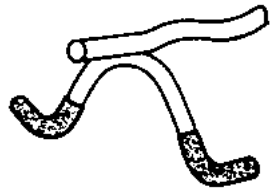

Baked on Plastic Feet

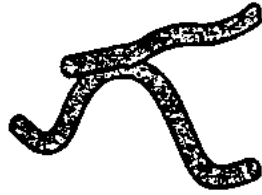

Epoxy-Coated

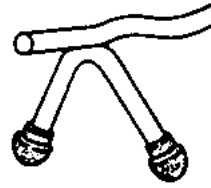

Plastic Tipped Feet

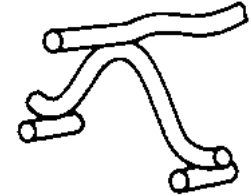

Stainless Steel Tips

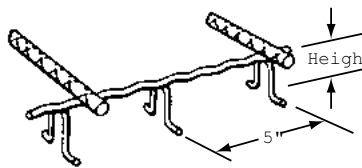

SB-Slab Bolster

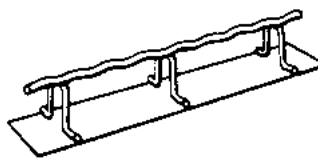

SBP-Slab Bolster with Plate

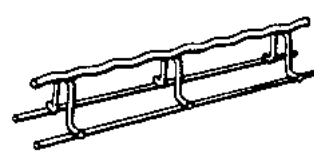

SBU-Slab Bolster Upper



JC-Joist Chair

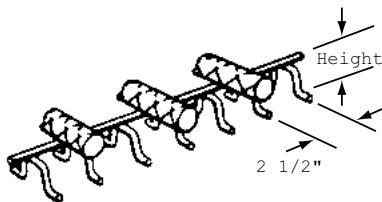

BB-Beam Bolster

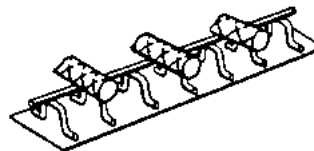

BBP-Beam Bolster with Plate

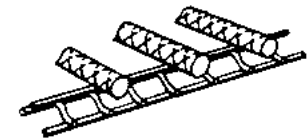

BBU-Beam Bolster Upper

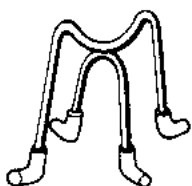

HC-Individual High Chair

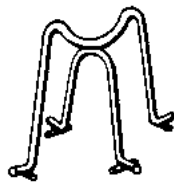

HCP-Individual High Chair with Plates



FHC-High Chair for Fill



BC-Bar Chair



BCP-Bar Chair with Plate

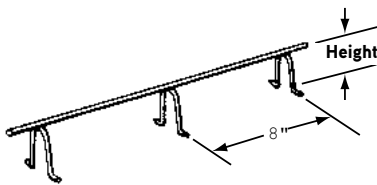

CHC-Continuous High Chair

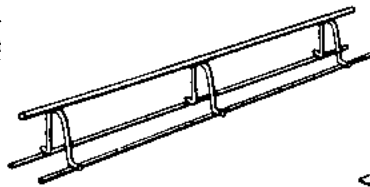

CHCU-Cont. High Chair Upper

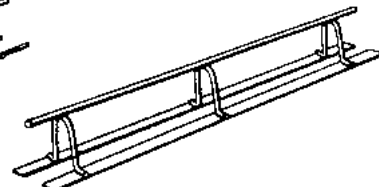

CHCP-Cont. High Chair with Plate

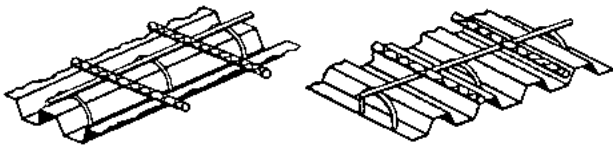

CHC-Continuous High Chairs for Metal Decking

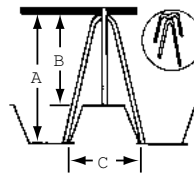

CHC-Continuous High Chairs for Metal Decking

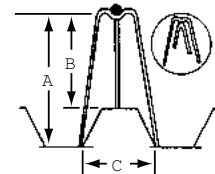

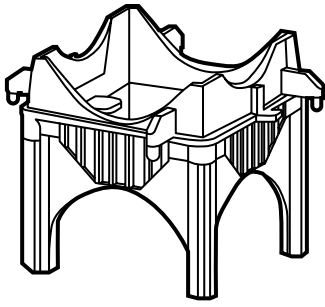

PBC-Tower Bar Chair

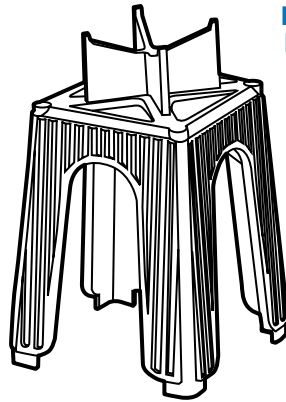

PTC-Tower
High Chair

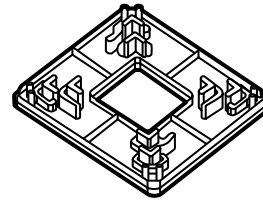

PTCSB-Tower Chair
Sand Plate

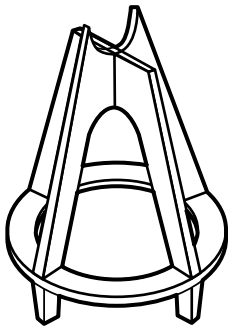

PEZ-Plastic E-Z Chair®

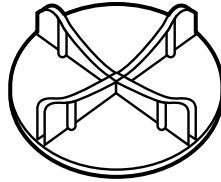

PSP-Sand Plate

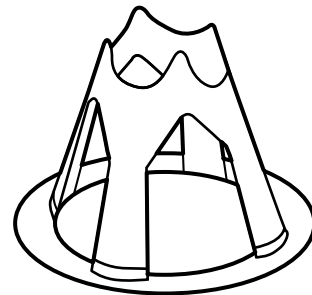

PCC-Castle Chair

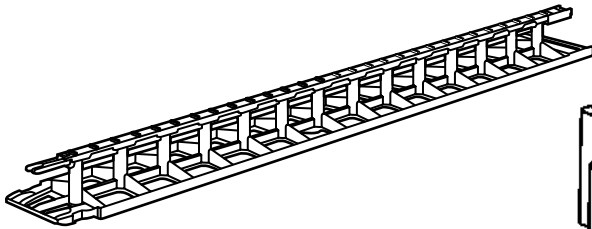

PSBU-StrongBack SBU™

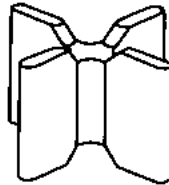

PXC-X-Chair

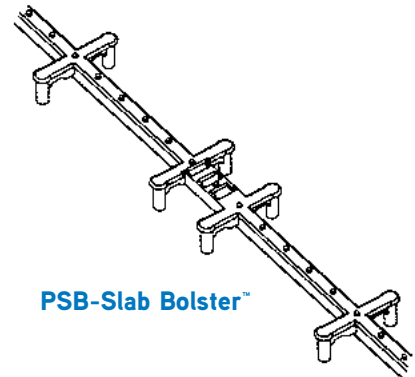

PSB-Slab Bolster™

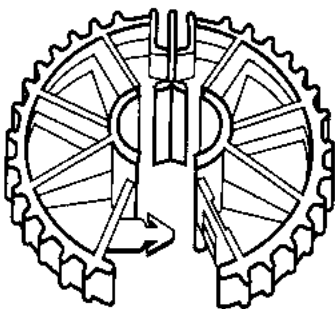

PLW-E-Z Lok Wheel™

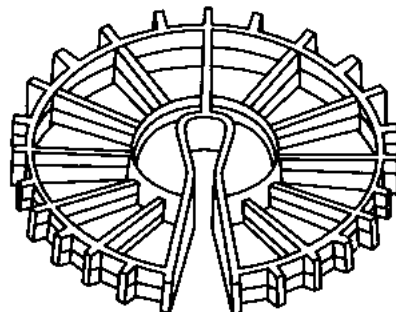

PSW-Space Wheel

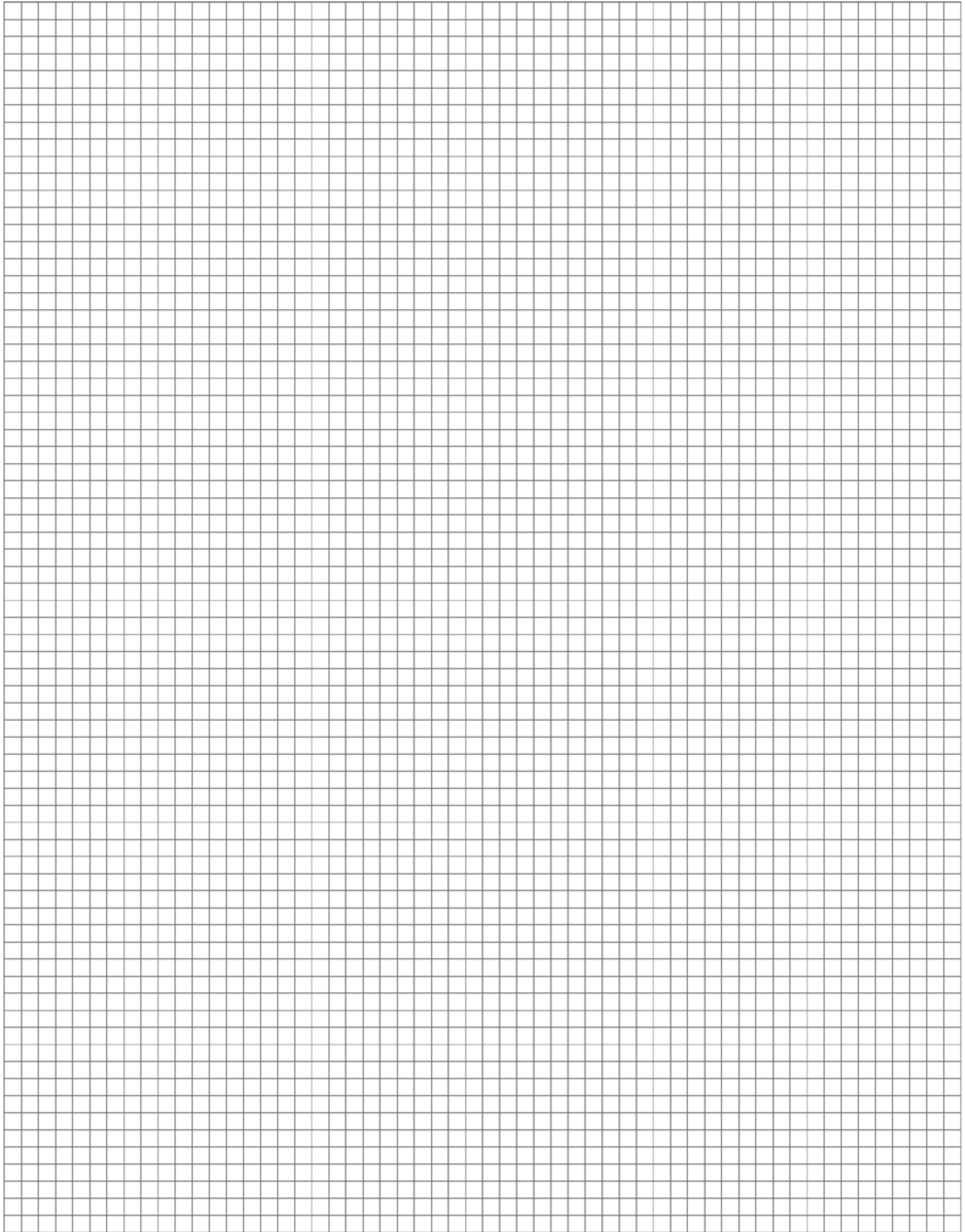

90° Hooked Dowel Bar Splicer	12	D158	50
90° Hooked Dowel-in	11	D158B	49
180° Hook Bar Threaded One End	17, 18	D158C	49
180° Hooked Dowel Bar	12	D158D	49
180° Hooked Dowel Bar Splicer	12	D158E	49
180° Hooked Dowel-In	11	D220	23
Attachment Magnet	58	D250L	22
Bag Ties	55	D250SCA	22
Bar Chair	58	D250XL	23
Bar Chair with Plate	58	D251L	24
Bar Lock Compression Only Coupler	26	D252L	25
Bar Lock Coupler System	21	D260	27
Bar Lock L-Series Coupler	22	D310	32
Bar Lock L-Series End Anchor	24, 25	D320	33
Bar Lock S/CA-Series Couplers	22	D330	35
Bar Lock Transition Couplers	23	D340	37
Bar Lock Weldable Couplers	27	D350	38
BB	59	D351	39
BBP	59	D358	40
BBU	59	D360	41
BCP	60	D368	42
Beam Bolsters	59	D370	43
Castle Chair	61	D382	43
CHC	60	D410	45
CHCP	60	D487	46
CHCU	60	D490	46
Chemical Composition Requirements for Standard ASTM		D491	46
Deformed Reinforcing Bars	3	D492	46
Continuous High Chair Upper	60	D493	46
Continuous High Chair	60	D630	26
Continuous High Chairs for Metal Decking	60	DBDI Splice System	9
D42	55	DBDI Weldable Coupler	15
D46	55	DBR 90° Hook Bar	17, 18
D48	55	DBR Coupler	16
D50	16	DBR Coupler System	16
D51	17	DBR Setting/Splice Bars	16
D51A	18	DBR Straight Bar Threaded Both Ends	17, 18
D52	17	DBR Straight Bar Threaded One End	17, 18
D52A	18	Deformation Requirements for Standard ASTM Deformed	
D53	17	Reinforcing Bars	3
D53A	18	Development of Standard Hooks	5
D54	17	Double End Anchor	49
D54A	18	Double-Ended Dowel Bar	12
D55	56, 57	Double-Ended Dowel Bar Splicer	12
D58	52	Double-Ended Dowel-In	11
D58A	53	Dowel Bar	51
D101	11	Dowel Bar Splicer System	9
D101A	12	Dowel-In	51
D102	11	End Anchor	48
D102A	12	End Anchorage System	48
D103	11	E-Z Chair	61
D103A	12	E-Z Lok Wheel	61
D104	11	F72	58
D104A	12	F74	58
D106	15	Female End Anchor	49
D108	51	FHC	59
D108A	51	HC	59

HCP	59	Table 1.10	5
Headed DBR Male Bar	52	Table 1.11	6
Headed Dowel Bar	49, 53	Table 1.12	7
Headed Dowel-In	49	Taper-Lock	30
High Chair for Fill	59	Taper-Lock End Anchor Disc	38, 39
Hooked Dowel Bar	12	Taper-Lock Female Bolt Head	40
Hooked Dowel-In	11	Taper-Lock Flange Coupler	37
Individual High Chairs	59	Taper-Lock Form Saver	42
Male End Anchor	49	Taper-Lock Positional Coupler	35, 36
Mechanical Requirements for Standard ASTM Deformed Reinforcing Bars	2	Taper-Lock Standard Coupler	31, 32
Mechanical Splice ACI and ICC Code Requirements	3	Taper-Lock Threaded Bar	43
MetalStrip	56, 57	Taper-Lock Threaded Plug	43
Metric Conversion Factors	7	Taper-Lock Transitional Coupler	33, 34
P154	58	Taper-Lock Weldable Coupler	41
PBC	61	Technical Assistance	1
PC110	55	Tension Lap Splice Lengths	6
PCC	61	Threaded Bar	43
PEZ	61	Threaded Plastic Setting Plug	58
Plain End Anchor	46	Threaded Plug	43
Plastic E-Z Chair	61	Threaded Steel Setting Plug	58
PLW	61	Tie Wire	55
PSB	61	Tower Bar Chair	61
PSBU	61	Tower Chair Sand Plate	61
PSP	61	Tower High Chair	61
PSW	61	Turbo Grout LT 12	46
PTC	61	Two-Piece End Anchor	50
PTCSB	61	X-Chair	61
PXC	61	XL-Series Coupler	23
Rebar Safety Caps	55		
Recommended End Hooks	4		
Recommended Industry Practice for Stirrup and Tie Hooks	5		
Reinforcing Bar Data	2		
Safety Notes	1		
Sand Plate	61		
SBP	59		
SBU	59		
S/CA-Series Couplers	22		
Slab Bolsters	59		
Sleeve-Lock ¾" SCH40 PVC	46		
Sleeve-Lock Form Plug	46		
Sleeve-Lock Grout	46		
Sleeve-Lock Grout Sleeve	45		
Sleeve-Lock Port Plug	46		
Sleeve-Lock Seal Plug	46		
Space Wheel	61		
Splicing Selection Guide	8		
StrongBack SBU	59		
Sure-Guard Rebar Protective Cap	55		
Table 1.1	2		
Table 1.2	2		
Table 1.3	3		
Table 1.4	3		
Table 1.5	3		
Table 1.6	4		
Table 1.7	4		
Table 1.8	5		
Table 1.9	5		





DAYTON[®] SUPERIOR

1125 Byers Road
Miamisburg, OH 45342
937-866-0711
888-977-5600

BUILDING STRENGTH™

DS3
05/19

Copyright © 2018 Dayton Superior Corporation, All Rights Reserved.